



ARIEL

THE MODERN MOTOR CYCLE

**OWNER'S
GUIDE
1953-54**

500 c.c.

TWIN CYLINDER

MODELS K.H. and KHA

ARIEL

OWNER'S GUIDE 1953-54

500 cc.

TWIN CYLINDER
MOTOR CYCLES

MODELS K.H. and K.H.A.

ARIEL MOTORS LTD.
SELLY OAK · BIRMINGHAM

Telephone:
SELLY OAK 1381

Telegrams:
ARIEL, SELLY OAK

INTRODUCTION

The information given in this book has been collected and compiled for your guidance by members of our Technical Staff who are practical motor cyclists of many years' standing and careful study of its contents will enable the owner to keep his machine in first-class running order by carrying out adjustments and repairs when necessary in a correct manner. Should any difficulty arise, however, our Technicians are always pleased to advise on any matter.

The following interesting literature is also supplied with every new "Ariel" Motor Cycle :—

- Lucas Lighting and Ignition.
- Chains and the Motor-cyclist.
- Tyres by Dunlop.
- Amal Hints and Tips.

When sending an enquiry, always state the Engine and Frame Numbers so that we can identify the exact specification of the machine. The Engine Number and Letter is stamped on the drive side crankcase immediately below the cylinder flange, and the Frame Number is stamped on the right-hand side of the saddle lug. We advise owners to make themselves conversant with all aspects of their machine by reading carefully the literature supplied.

ENGINE

RUNNING-IN

Careful running-in of a new machine is of the utmost importance, because it allows the pistons and cylinders to become seasoned by frequent heating and cooling and all bearings to acquire first-class surfaces, resulting in a prolonged life and high efficiency. Misuse during the first few hundred miles will lead to unnecessary trouble and dissatisfaction to the owner.

Running-in road speeds cannot be given exactly, as so much depends upon road conditions, but providing the engine is running freely on small throttle openings, speeds in top gear up to 35 m.p.h. will be safe for the first 500 miles, increasing to 40 m.p.h. for the next 250 miles. Do not open out to full power under 1,000 miles, and then for short distances only until approx. 1,500 miles have been covered.

Check all bolts, nuts, and screws for tightness during the running-in period in case any have slackened off. A number of proprietary brands of running-in compound containing colloidal graphite are on sale and can be used generally according to the maker's instructions.

FUEL, OIL AND GREASE

Good quality oil and grease should always be used, especially during the running-in period. The various brands of lubricants shown on page 82 are the ones used exclusively in our works for all engine bench and road testing, and we strongly recommend the use of one or the other of them according to individual preference. Castor oil is not recommended for these machines.

Oil consumption depends to some extent on driving speed but should average 2,000 m.p.g. over a long period. The only fuel available in this country at present is about 72 octane, but if 80 octane becomes available (or our overseas customers can obtain it) it can be used without alteration to the carburettor setting and will give improved all-round performance.

Fuel consumption under normal touring conditions should average solo 75/80 m.p.g., sidecar 60/65 m.p.g. These figures do not apply to new machines whilst "running-in."

INSTRUCTIONS FOR STARTING

Easy starting is usually an indication that the engine is in good condition; if therefore, difficulty is experienced something is out of adjustment and the trouble should be remedied without delay. For starting when the engine is cold the carburettor should be flooded slightly, the twist grip throttle set just off the shut position, and the kick-starter used in the ordinary way. When the engine has started, allow the kick-starter to return to its normal position immediately; also see that the oil gauge is indicating the correct pressure (see notes on page 13). Ignition timing is automatically set in the retarded position for starting. In very cold weather the air control should be closed by depressing the knob on the control slide and giving it a part turn to lock it in the closed position. Release as soon as the engine starts. The carburettor throttle stop is set at the factory to give a steady tick-over of the engine when warmed up with the twist grip in the shut position. To stop the engine, press the button switch on the magneto contact breaker cover.

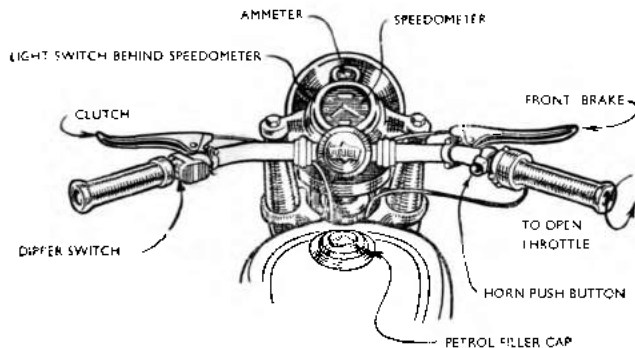

Fig. 1. Showing Controls and Equipment.

TRACING MINOR TROUBLES

If the engine does not start easily, check as follows :—

1. Make sure fuel is getting to the carburettor. If the level in the fuel tank is low PULL on the reserve taps.

2. See that the carburettor fixing nuts are tight and that there is no air leak at the joint between carburettor and cylinder head.

3. Make sure the throttle valve moves in response to the twist grip movement—the wire may be faulty. See that the slow running adjustment is correctly set.

4. See that there is no fault with the H.T. leads from the magneto to spark plugs and that the leads have not been changed round to the wrong spark plug. Damp, soiled or perished rubber leads will cause difficult starting as well as moist spark plug insulation.

5. Test the spark by disconnecting the H.T. lead from one of the spark plugs, i.e., hold it about 1/16 in. away from the plug electrode and turn the engine with the kick-starter. If a good spark occurs the ignition system is in order.

6. If a good spark does not occur as above, examine the magneto contact breaker points, which should always be clean and open and close as the engine is rotated. (See Lucas booklet or B.T.H. notes)

7. Examine the spark plugs, clean the insulation thoroughly, and set the points to .020 in.

8. If a choked main jet is suspected, this can be readily inspected by unscrewing the nut at the bottom of the carburettor body. (See Amal leaflet).

9. Test the compression by depressing the kick-starter pedal. The valve rocker adjustment may be set too close, preventing the valves from seating properly.

ERRATIC RUNNING

If the engine starts but runs erratically, check the following after the engine has warmed up :—

1. Judge by the exhaust note which cylinder is giving trouble.

2. Check over all points mentioned under heading "Tracing Minor Troubles" especially No. 7.

3. Check valve rocker clearance and adjust to instructions on page 23. See that all valves are opening and closing properly when the engine is rotated.

4. Make sure the magneto cut-out switch has not been deranged to cause a short circuit.

5. A shortage of fuel in the carburettor can be traced by operating the tickler. See that the vent hole in the fuel tank filler cap is quite clear.

6. See that the air control slide is in the open position.

DRIVING HINTS

1. It is usual to start away by engaging the lowest gear, changing to the higher gears as the engine gathers speed. The gear change pedal movement is down for the next higher gear and up for a lower gear. Neutral can be found by changing through the gears to the lowest, then moving the pedal half a stroke downwards. A dragging clutch due to incorrect adjustment makes neutral finding difficult. The pointer on the gearbox indicates neutral. (See "Gearbox" Notes.)

2. To engage low gear without noise after the machine has been standing some time, it is advisable to free the clutch-plates before the engine is started, by depressing the kick-starter once or twice, while the clutch is held out of engagement by the handlebar lever.

3. A silent gear change can be made if, when changing from a lower to a higher gear, the throttle is eased off and a slight pause is made in neutral position, halfway between the gears. The length of pause will depend on the engine revs., but a little experience will soon indicate the length of pause required.

4. When changing from a higher to a lower gear, leave the throttle partly open, so that the engine speeds up as soon as the clutch is released, then move the gear quickly, allowing the clutch to slip during the change.

5. Do not let the engine labour in a high gear, especially when sidecar is fitted, but change down and get improved engine flexibility. The engine is designed to give its best all-round performance at fairly high revs. If you are used to a single cylinder engine, do not mis-judge engine revs. of the twin by the exhaust note which, of course, has twice the frequency of a single cylinder unit.

6. Do not open throttle suddenly at any time and do not "blip" the throttle when waiting in the traffic or starting away. The engine will continue to tick over if the throttle stop is set correctly. (See Amal leaflet.)

7. Do not remain "in gear" long with the machine stationary and the clutch withdrawn, but change into neutral and release clutch.

8. Study the "Highway Code."

DESCRIPTION OF ENGINE

Model KH—See *Exploded View inside rear cover*.

Model KHA—See *Page 11*.

The four-stroke engine has two vertical cylinders in a monobloc casting 63mm. bore, 80mm. stroke, giving a total cubic capacity of 498c.c. (2.48in. bore, 3.15in. stroke, 30.4 cubic inches).

Both pistons rise and fall together, giving one power stroke for each crankshaft revolution and even spacing of the induction and exhaust strokes. The remarkable absence of engine vibration is obtained by balancing the pistons and connecting rods by counterweights integral with the forged two throw crankshafts and similar weights cast integral with the permanently mounted central flywheel. (See Fig. 2.)

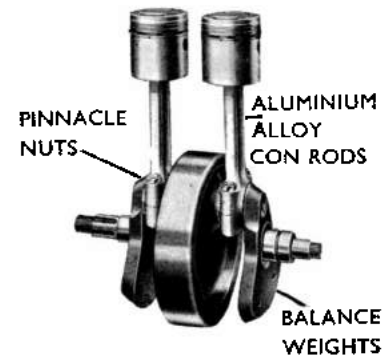

Fig. 2.

The crankshaft is carried on a large roller bearing on the drive side and a white metal lined journal bearing on the timing chain side which is also provided with large thrust faces for locating the crankshaft endways. Adjustment for wear can be made by removing one of the shims situated behind the thrust washer which is secured by the timing sprocket nut.

Aluminium alloy pistons are carried on forged light alloy connecting rods by full floating gudgeon pins, the small ends of the rods are bushed and the large ends split and fitted with replaceable white metal half bushes or liners. (See Fig. 2.) The connecting rod cap is secured to the rod by two bolts and nuts—the nuts tighten against the rod and are accessible from above after the cylinder block has been removed, so that, if ever necessary, a connecting rod bearing can be renewed without further dismantling of the engine.

Twin Camshafts within the crankcase are driven from the crankshaft by duplex roller chain. Chain wear is automatically adjusted by means of a spring loaded tensioner blade bearing against the underside of the chain. An adjustable stop piece makes contact with the moveable end of the blade to prevent reverse movement. The stop piece can be moved into contact when chain wear makes this necessary. Allow .010in. clearance between the stop piece and blade end on a cold engine and readjust when the clearance due to chain wear exceeds $\frac{1}{32}$ in.

The **6-volt dynamo** is driven from the front camshaft by gearing at one and a quarter times engine speed.

The **Flange-mounted magneto**, with its automatic ignition timing control, is gear driven from the rear camshaft. The twin cylinder magneto runs at half engine speed. The gear, complete with ignition control unit, can be withdrawn from the magneto spindle by un-screwing the central hexagon sleeve nut extractor. (See Fig. 3, and exploded view). Riveted to each camshaft chain sprocket is the gear for driving the Magneto and Dynamo respectively. These gears are manufactured from a special "Millenite" metal. The chain sprockets are identical and interchangeable but the driving gears are machined as follows. "MILLENITE" gear for magneto 59 teeth, "MILLENITE" gear for dynamo 57 teeth.

A **double-gear-type oil pump**, situated at the base of the crankcase, is driven from the rear camshaft by spiral gears and a long vertical shaft terminating in a tongue coupling to the pump. Thrust of the pump shaft spiral gear is taken by a spring-loaded ball fitted into a plug at the top of the crankcase in which is also incorporated a crankcase pressure release system.

Twin camshafts, hardened and ground throughout are carried on phos. bronze bushes, those of the sprocket end having larger thrust faces for positioning the shaft endways. Adjustment for wear can be made by fitting a thinner shim behind the sprocket.

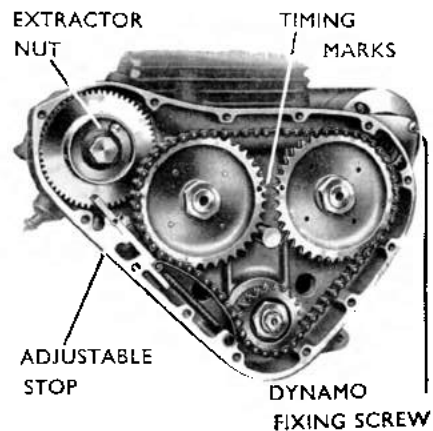

Fig. 3. (See page 20.)

Models KH—KHA.

The **spherical combustion chambers** of the cast-iron cylinder heads have inlet and exhaust valves at 80° to each other, operated by spring-loaded overhead rockers, each mounted on a hollow spindle supported by extensions of the head casting and supplied with oil under pressure from the main system. (See Fig. 4). The rockers are operated from the twin camshafts by ball-ended push rods and flat based tappets.

MODEL "KH".

The **cast-iron cylinder block** is secured to the crankcase by a flange and eight accessible studs and nuts. A joint washer is used between the cylinder block and crankcase face. The flat base tappets are supported by cast-iron guides, a press fit in the block and retained by a spring steel circlip. A copper and asbestos washer is fitted between the cylinder block and cylinder heads and eight studs and nuts ensure a pressure-tight joint. (See Figs. 7 and 8.)

MODEL "KHA."

The Model "KHA" is a light alloy engine version of the "KH" incorporating a cylinder block cast in Lo Ex Silicon alloy with pressed-in liners.

The cylinder head is cast in Y alloy and valve seat inserts of austenitic iron are pressed in.

The cylinder block and head securing bolts are of the extended type located at the lower end in steel thimbles in the crankcase and screwing into bronze inserts in the cylinder head. Each securing bolt incorporates two hexagons brazed together out of relation thus allowing twelve spanner positions per revolution. This method of fixing and operating enables the tightening down of the head and block to be carried out without difficulty. See Fig. 6. Page 12.

FOURWAY OIL CONNECTIONS TO
ROCKER SPINDLES

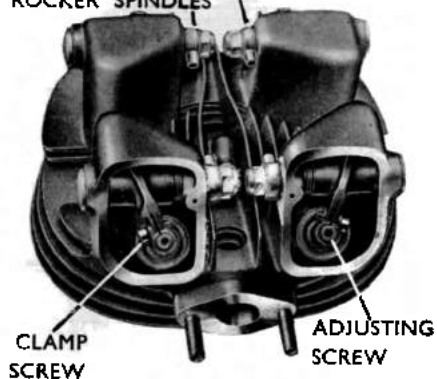

Fig. 4. Model KH

ENGINE LUBRICATION EXPLAINED

The double oil pump consists of two independent pumps—for supply and return—built into a common body and surrounded by an efficient gauze filter which can be dismantled for periodic cleaning by unscrewing four nuts and removing the cover plate at the bottom—rear—of the crankcase.

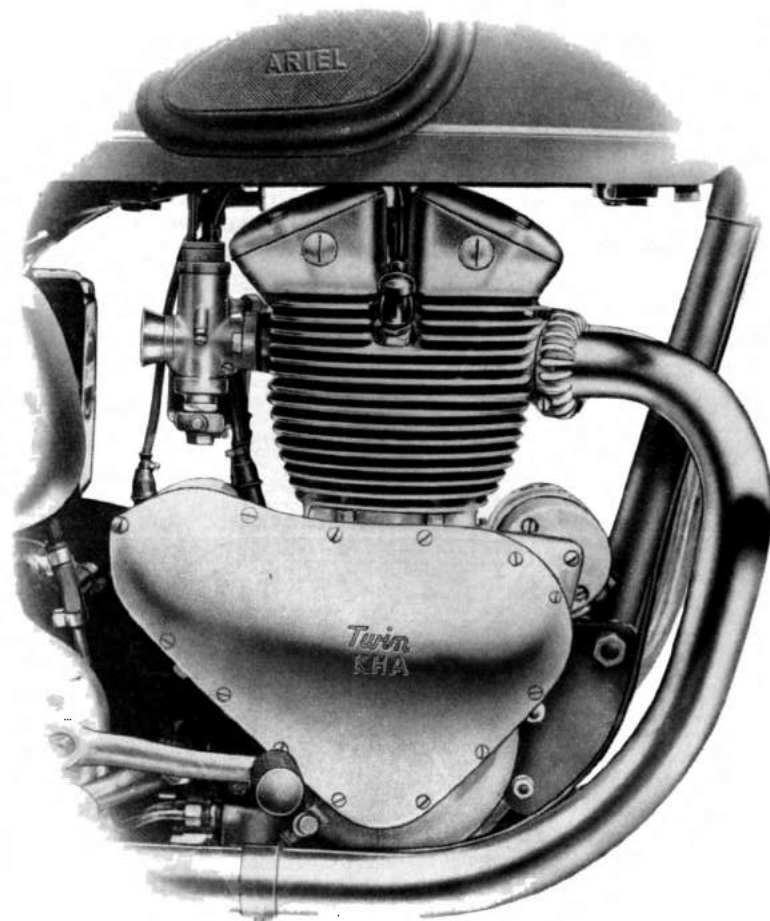

Fig. 5.
The Model KHA Light Alloy Engine.

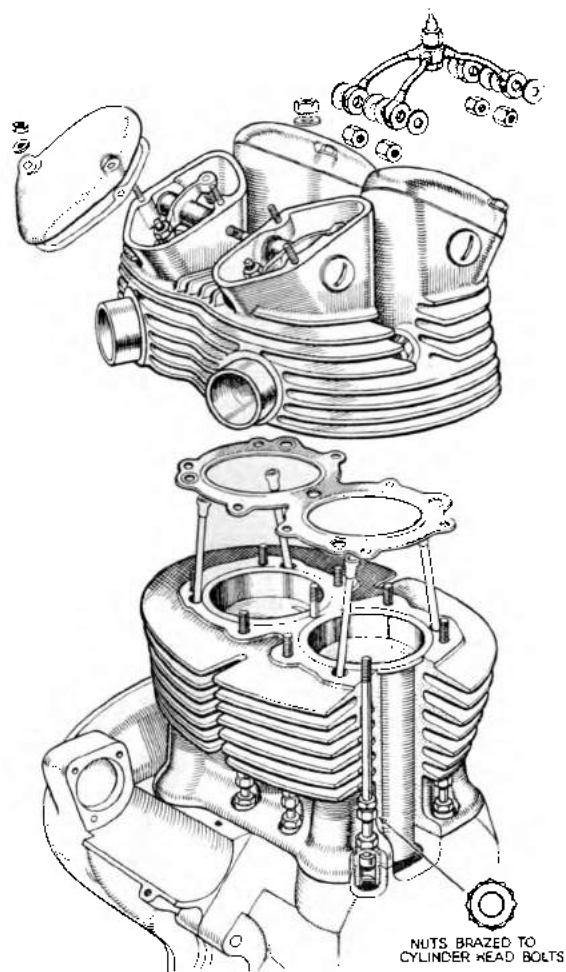

Fig. 6.

The Model KHA Cylinder Block—Cylinder Head and Extended Securing Bolts.

By courtesy of "The Motor Cycle."

Oil is drawn from the bottom of the oil tank by the supply pump and forced under pressure to the crankshaft bearing and thence through the hollow crankshaft to each connecting rod bearing; a secondary supply is taken to the overhead rockers with a further extension to the pressure gauge in the fuel tank panel. Constant pressure is maintained throughout the system by a release valve in the end of the crankshaft. Lubrication of all other internal parts of the engine is by splash with suitable channels and holes for directing it to each particular bearing. After passing through the bearings, the oil drains into the sump and is pumped back into a second oil filter inside the oil tank. This filter can be detached for cleaning after removing the filler cap.

JOINT FACE AND STUD HOLES



TAPPETS AND GUIDES

Fig. 7.

Oil tank and Filters. Do not allow the level to fall below the "minimum level mark" on the tank, or there will not be sufficient oil for complete circulation. The oil tank and engine sump should be drained after the first 500 miles and the tank and filters thoroughly cleaned in petrol. The operation should be repeated every 2,000, 3,000 miles. Our overseas customers riding in dusty or sandy conditions should clean out the tank and sump more frequently. Always remember to refill the oil tank.

HOW TO TRACE LUBRICATION FAULTS

The normal oil pressure (gauge reading) is 25 lbs. per square inch. The pressure may rise above this figure when the

engine is started from cold, but will fall to normal as the engine warms up. The pressure is controlled by a non-adjustable relief valve situated in the end of the crankshaft, and the gauge pressure may be slightly above or below the normal without causing alarm, providing it is constant, because the capacity of the oil pump is such that it can supply more than four times the amount which the bearings can take irrespective of the pressure, so that a large quantity of oil is always being by-passed into the sump and back to the oil tank. The important point is that the pressure gauge gives a clear indication that oil is being fed into the engine and by unscrewing the oil tank filler cap the complete circulation can be observed as oil returns to the tank. On no account ride the machine unless the oil is circulating properly. By process of elimination, lubrication faults can be quickly discovered as follows :—

If the gauge does not record a pressure :—

1. Examine oil level in tank. It may be below normal.
 2. Examine oil pipe connections from tank to engine at four points for leakage. On the supply side (the pipe nearest the centre of the machine) it may be sucking in air.
 3. Examine oil pipe connections to pressure gauge and rocker spindles at eight points for oil leakage.
 4. Loosen the nut at the side of the crankcase near oil pump, half a turn. If oil exudes freely from this connection when the engine is running there is some fault in the passage-way to the gauge or in the gauge itself. It may be that the gauge hand has stuck and a slight " tap " will release it.
 5. If the oil pipe to the pressure gauge is blocked it can be cleared by passing a wire through it or with air pressure.
 6. If there is no fault with the pressure gauge or connections but it still records little or no pressure and oil returns to the tank in the usual quantity when the engine is running, it is probable that although oil is circulating freely, a pressure cannot be built up to operate the gauge because of a leakage in the system, most likely at the relief valve.
- Undo the screws and remove the timing cover. Unscrew the hexagon-headed valve in the end of the crankshaft and examine. (See exploded view).

If dirty wash in petrol and also clean out any foreign matter which may have collected in the crankshaft hole before replacing the valve.

7. A fault in the oil pump is most unlikely, but it can be checked if the fault persists. Remove the sump cover, and gauze by unscrewing four securing bolts. Next undo four screws securing the oil pump to the crankcase, when the pump complete can be pulled away. Examine the pump but do not dismantle unless necessary. When replacing the pump take care to engage the slot on the driving shaft with the tongue on the oil pump spindle.

HOW AND WHEN TO DECARBONISE

The mileage at which an engine will run efficiently without being decarbonised depends to a large extent on how carefully it has been driven and maintained.

A new engine, carefully run in, should be decarbonised for the first time at approximately 2,000 miles as more excess oil and carbon is deposited in the combustion chambers during the above period than will be the case when pistons and rings have taken on good bearing surfaces.

Broadly speaking, the harder the machine is driven, the more frequently should it be decarbonised, which of course includes grinding in valves.

Indications that this work should be undertaken are :—

1. Engine " pinking " at say half throttle.
2. Lowering of general performance.
3. Poor compression, indicating bad valve seats.

Under average conditions the engine should be decarbonised every 8,000 to 10,000 miles, but if the general road performance has not deteriorated appreciably, the period can be extended.

MODEL " KH "

To remove the cylinder head, follow these instructions carefully :—

1. Raise the petrol tank, remove exhaust pipes, carburettor, petrol pipes, rocker box covers, spark plugs and oil pipes from crankcase to central joint near rocker spindles and oil gauge pipe, but not the four-way connection to the rocker spindles. (See exploded view).

2. Unscrew the eight cylinder head securing nuts, situated between the second and third fins of the cylinder block about $\frac{1}{8}$ in. or four complete turns. The cylinder head can then be

raised off the cylinder block enough to pass two thin spanners or other packing between the two. (One piece on each side of the cylinder). Do not force the packing in or the joint washer will be damaged. (See Fig. No. 8.)

Next unscrew all the nuts from the studs and lift off the head complete, leaving the eight nuts resting on the cylinder fins, which can be removed later. As the head is lifted the four push rods must be lifted also and held up until quite clear of the cylinder; then the head can be drawn away to one side. Mark the push rods so that they are replaced in their original positions. It is not necessary to remove the cylinder block unless some fault with the piston or rings is suspected. The piston tops can be scraped clean "in position" if the engine is turned to bring them to the top of the stroke.

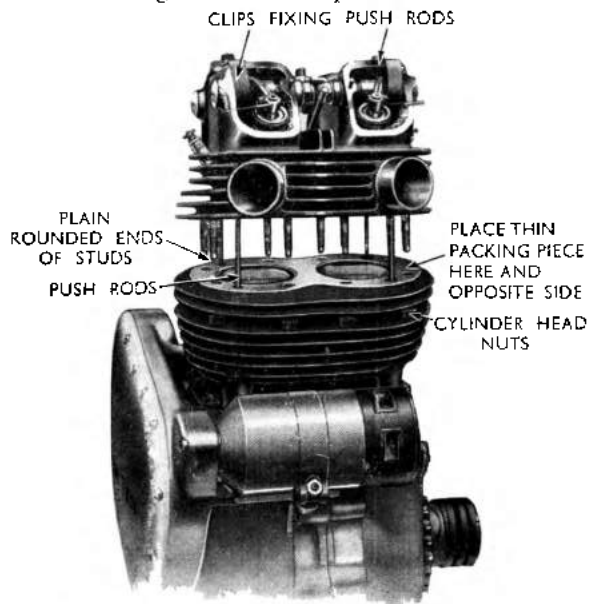
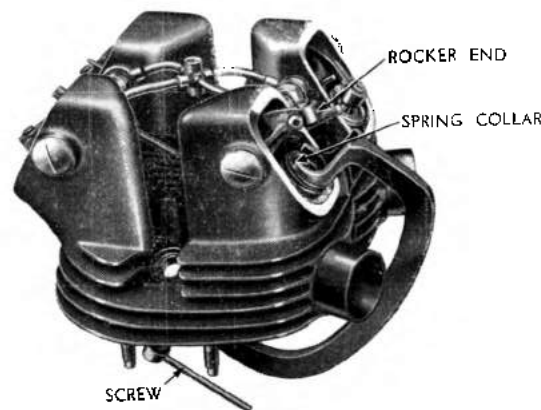

Fig. 8. Model KH

If it is necessary to remove the cylinder block, first turn the engine until the pistons are at the bottom of the stroke, then unscrew the eight fixing nuts at the base and lift the block carefully so that the pistons slide out of the cylinder freely, taking care that the four tappets do not catch in the holes in the crankcase in which they operate. It is wise to leave the tappets in position, but they can be removed by giving each a pull to overcome the resistance of a small steel circlip fitted in the tappet stem recess. Mark each tappet and be sure to re-assemble them in their original positions.



Model KH Fig. 9.

To grind the valves. The valve springs are retained by the usual split cotters and can be removed with the aid of a spring compressor tool (obtainable from most accessory dealers). It is not necessary to disturb the valve rockers, as they will rotate on their spindles out of the way. (See Fig. 9.) Turn rocker ends upwards to allow one end of the valve removal tool to press against the valve spring collar, the other end (with screw thread) to engage the centre of the head of the valve. Turn the compressor screw until the valve spring is compressed enough to release the split cotters fitted round the valve stem.

Keep the valve springs and cotters to their respective ports. Scrape all carbon from the cylinder head, ports, valve heads and grind the valves in the usual manner with fine grinding paste.

Wash all parts thoroughly in paraffin and assemble in the reverse manner to dismantling, but note the following :—

If the cylinder has been removed take care not to damage the pistons or rings when assembling them in the bores.

The easiest method is to use ring clips (obtainable from accessory dealers) to hold the rings compressed while the cylinder is being replaced. See that the base washer is in good condition and that the cylinder is reassembled (it can, but must not be reversed) as originally fitted.

Replacing the Cylinder head. See that the joint faces of the head and cylinder block are perfectly clean and the joint washer in good condition. Do not use jointing compound. Check the eight cylinder head nuts on the studs to make sure the threads have not been damaged during handling, then place each of the nuts between the second and third fins of the cylinder block and accurately locate them opposite the eight holes in the block by means of the tommy bar provided. Replace the push rods into the cylinder head and hold up while the head is being replaced. To enable ease of operation, the push rods and rocker levers can be held against the top of the rocker housing by using some form of improvised clip, and such an arrangement is illustrated in Fig.8. Place the spanners or packing pieces in position on the cylinder block to support the head while the nuts are engaged with the threads on the studs. Note that the studs have spherical ends to "pick up" the nuts as the head is lowered on to the cylinder block. Screw the nuts three or four complete turns, remove the packing and finally tighten all nuts.

Adjust valve clearances as described on page 23.

When replacing the carburettor see that the joint washers each side of the insulating block are in good condition, because an air leak at this point will cause erratic running. Retighten the cylinder head nuts after the first 50 miles or so, because the head washer settles a little with the heat. This is particularly important if a new head washer has been fitted or on a

new machine and should be repeated several times during the first 1,000 miles. Do not forget to check the valve clearances because it will be reduced as a result of any settling down of the head washer.

MODEL "KHA"

Removing Cylinder Head and Cylinder Block.

To remove the cylinder head for decarbonisation it is advisable for ease of operation to raise or completely remove the petrol tank.

Next take off the exhaust pipes, carburettor, petrol pipe, rocker covers, and sparking plugs.

Release the oil pipe union to rocker assembly.

The cylinder block incorporates a ninth head securing stud centrally positioned between the bores on the top face. To remove the nuts from this stud it is necessary first to take off the four-way rocker oil feed pipe assembly. To remove this assembly it is necessary to take out the rocker spindles one of which can be partly forced out by unscrewing the hexagon spindle securing nuts against each other. After finally driving out the first spindle the second or opposite one can be driven out by passing a suitable drift or punch through the vacant spindle holes.

After releasing the eight extended bolts and the centre securing nut, the cylinder head and barrel can be lifted clear of the crankcase. The push rods are removed from the cylinder head after taking out the rocker spindles and rockers following the removal of the oil pipe assembly to rocker boxes. After decarbonisation has been carried out the joint faces of the cylinder head and barrel should be very lightly "rubbed" down on a flat surface plate using a little fine emery paste or cloth and a new head joint washer prepared for refitting. When tightening down the extended securing bolts, commence with the four central ones in a diagonally opposed order repeating the sequence with the remaining four. Gradually tighten in the order named until the head and block are secure.

Piston and cylinder wear. The pistons are of wear-resisting aluminium alloy and under normal conditions should have a life of at least 20,000 miles.

When ultimately wear has taken place to cause piston rattle and excessive oil consumption, the cylinder block can be rebored .010 and .020 ins. over-size (in two stages) and over-size pistons and rings fitted. The two compression rings have a side clearance of .002in. in the piston grooves when new, and a gap between the ends of the rings when measured in the cylinder bore of .008 .012 in.

Rings should be replaced when, due to wear, the gap exceeds .040in., but if the cylinder bore has worn excessively a rebore is advised. The scraper ring has similar clearances when new and should be replaced when, due to wear, the gap exceeds .070 in. Gudgeon pins are retained in the pistons by spring rings, which should be removed carefully with a sharp pointed tool. They must snap tightly into the groove in the piston when refitted.

Dismantling the whole engine. Owners are not advised to undertake this work unless they have considerable mechanical ability. Removing the cylinder block and head has already been described.

MODELS "KH" AND "KHA"

Camshaft driving chain. Before removing the camshaft chain and sprockets, note the punch marking on the sprockets as this will be of assistance when reassembling and setting the valve timing. Rotate the crankshaft until the dot on the crankshaft sprocket is on top and a dot on one camshaft sprocket is *almost* opposite a dot on the other. Note then the position of the second dot on each camshaft sprocket which should be at the lowest bottom position and *almost* directly under each camshaft centre.

First remove the chain tensioner complete and the three nuts securing the sprockets to their respective shafts.

Three special extractors are desirable (it can be done with one) to withdraw the sprockets with chain in position from their shafts. Screw the extractors home and rotate each central screw of the extractor equally and in turn so that all three sprockets are drawn off together. (See Fig. 3.)

To remove the magneto. Unscrew the central fixing nut, which also acts as an extractor, and the gear, complete with

control unit, will come away. The control unit should not be dismantled but replaced as a whole if faulty. The magneto body is secured by a flange and three nuts to the back face of the timing gear chest.

To remove the dynamo. This can be done if necessary without dismantling any other part of the engine. Loosen the fixing strap, undo the securing nut near the timing cover and slide the dynamo out, complete with gear wheel. On the earlier models three screws secured the dynamo, two of them passing through the timing cover.

To remove the crankcase from the frame it is necessary to take off the outer primary chain case, primary chain, and dismantle the clutch and engine shock absorber. (See notes "Clutch and Gear Box.")

Next the inner chain case, engine plate bolts, then the whole crankcase can be lifted out of the frame.

By separating the two halves of the crankcase the crankshaft and two camshafts can be withdrawn.

Do not overlook the two pinch bolts below the top face (cylinder face) of the crankcase.

Replacing crankshaft bearings. If it is necessary to replace the crankshaft roller bearing, the outer ring can be removed by heating the half crankcase in boiling water and knocking the joint face on a wooden bench or similar, when the ring will drop out under the shock. The inner race must be driven off the shaft with a punch. Note when fitting a new race that the inner member must be a tight fit on the shaft and the outer ring pressed into the housing with the lip side in first. The timing side bush should be removed if renewal is necessary by means of a mandrel press.

Replacement timing side bearings can be supplied either prefinished to size or .010in. small for boring out to suit the shaft diameter. The diametral clearance when new, between crankshaft and bush, is .001in., and the bush should be renewed when the clearance has increased to .003in.

Crankshaft location. The crankshaft is located from the timing side bush faces only, there being a clearance of $\frac{1}{32}$ in. between the rollers and lip of the driving side bearing. The end clearance of .002/.004in. between the crankshaft face,

thrust washer and bush faces can be restored by means of shims of varying thicknesses. To check the end clearance, insert the crankshaft into the timing side bush only, tighten the thrust washer and shims against the shoulder on the shaft by means of a temporary sleeve and nut, and test with thickness gauges.

Camshaft location. The camshafts are both located in a similar manner to the crankshaft, by the thrust faces on the timing side bush. Adjustment for end clearance can be made with varying thicknesses of shims and the allowable end clearance is .001-.002 in.

Renewing connecting rod bearings. As previously mentioned, the connecting rods can be removed from above after taking off the cylinder block. Unscrew the pinnacle nuts securing the cap and gently pull the top part of the rod away, at the same time placing a piece of bent strip material underneath the cap to prevent it falling into the crankcase. When the rod is away the cap can be revolved round the journal and lifted off, together with the half bearing. If new half bearings are to be fitted, make sure that the crankshaft journal has not been scored or discoloured from heat. On no account file the face of the con rod or cap to take up bearing clearance, but fit new half bearings, which are supplied finished to size. Note when assembling that the key on each half bearing engages with the slot in the rod and cap and that the cap is fitted the right way round (see marking). The pinnacle nuts are self-locking.

In the case of a complete overhaul, before fitting new bearings, it is advisable to clean out the oilways in the crankshaft by unscrewing two large plugs and the relief valve and thoroughly washing with clean petrol.

The maximum safe diametral clearance due to wear in the connecting rod bearings is .003 in., after which new bearings should be fitted, but if the crankshaft has worn oval it can be re-ground .010 in. smaller and undersize bushes fitted.

The diametral clearance when new is .0005-.001 in., and the end clearance about $\frac{1}{32}$ in.

Assembling the Engine. Assembling the crankshaft and two camshafts into the crankcase calls for no special comment. When assembling the camshaft driving chain care must be taken to obtain the correct valve timing.

Timing Gear. First set the crankshaft so that the pistons are at the top of the stroke (Top dead centre) and the key of the crankshaft at the topmost position ("12 o'clock").

Next rotate the two camshafts until the keys are set approximately at "11 o'clock" INLET and "1 o'clock" EXHAUST respectively.

Place the timing chain over the three sprockets with the "DOT" markings *almost* opposite and then slide the sprockets on to their shafts again *almost* engaging the keys in this operation. The thrust washer and shims should previously have been positioned on the crankshaft.

Now strike an imaginary line through the centre of the camshaft sprockets and finally set these so that the "DOT" on the rear or inlet sprocket is 1.16 in. above the centre line and the "DOT" on the front or exhaust sprocket is 1.16 in. below the centre line.

Gently drive the sprockets on to the keyed shafts until the nuts can be started on the threads and finally tightened to force the sprockets home.

Fit the timing chain tensioner and adjust the sliding adjustable block to within .010 in. of the tensioner blade and tighten the nut securely. (See Timing Diagram Fig. 10).

Valve Timing. To check the valve timing first adjust the valve tappet clearances—Inlet and Exhaust—to .002 in. and note :—

The Inlet Valves open 15° or 1/16 in. before T.D.C.
The Inlet Valves close 55° or 9/16 in. after B.D.C.
The Exhaust Valves open 46° or 13/32 in. before B.D.C.
The Exhaust Valves close 20° or 1/8 in. after T.D.C.

After checking, readjust valve tappet clearances with engine as described below.

Valve tappet clearance. The engine should be cold and all cylinder and cylinder head nuts finally tightened before the tappets or rocker adjusters are finally set.

All first series 1952 engines with Serial Number Prefix Letters **TE** and a plain number only were fitted with a type of camshaft necessitating valve tappet clearances of :—

INLET valve .002in.

EXHAUST valve .002in.

All second series 1952 engines with Serial Number Prefix Letters **TE** and a Suffix Letter **C** and also all engines numbered from **TE 1258** to **TE 1768** as well as **all** 1953 engines with Prefix Letters **XF** and **XFA** (KHA units), were fitted with a type of camshaft necessitating valve tappet clearances of :—

INLET valve .005in.

EXHAUST valve .008in.

The tappet or rocker adjusting screw incorporates a square end for adjustment purposes and a small flat spanner is supplied. The screw is secured with a lock nut. Always ensure that the lock nut is finally tightened. Valve end caps are not fitted, all valve stems being specially treated to prevent wear.

Magneto timing. This can be done more easily on the complete engine, so that the position of the valve openings can be noted. If the timing is right for one cylinder, the other will be correct.

Rotate the engine until both valves of one cylinder are closed and the piston is at the top of the stroke—T.D.C. Then further rotate the engine very gently until the piston is set at four to eight degrees (equivalent to $\frac{1}{32}$ in.) **After Top Dead Centre.** Next turn the Magneto armature until the segment is opposite the H.T. pickup for the cylinder being timed and the contact breaker points are just on the point of opening. Tighten the spindle nut in this position taking care not to alter the setting whilst doing so. This gives the **fully retarded** ignition point. Next check the **fully advanced** ignition point by turning the armature with the fingers by

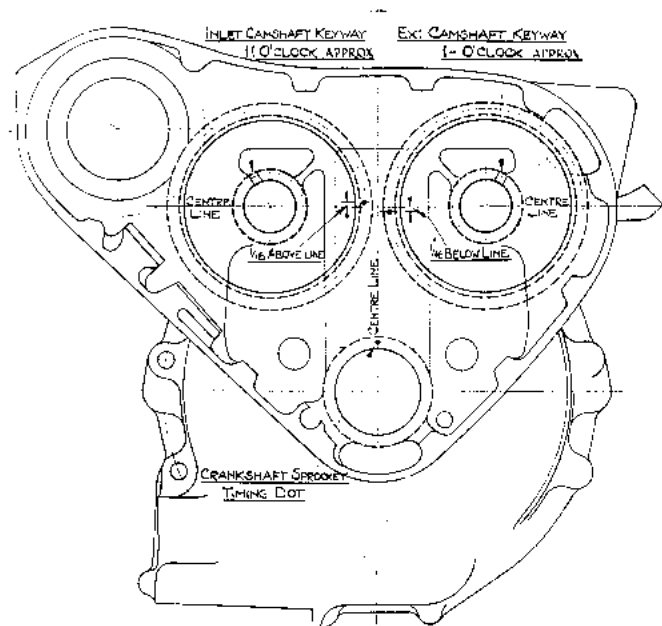

Fig. No. 10.
Valve Timing - Models KH—KHA.

means of the automatic control mechanism. With the control thus held in the fully advanced position the piston should be thirty degrees (equivalent to $\frac{1}{4}$ in.) **Before Top Dead Centre** with contact breaker points just breaking.

If there should be any variation in the range of advance and retard always adhere to the $\frac{1}{4}$ in. advanced position when setting the timing.

Sparking Plugs.

MODEL "KH."

For normal use: Lodge Short Reach "CN" or "C 14".
Champion Short Reach "I. 10 S".

MODEL "KHA".

For normal use: Lodge Long Reach "CB" or "CL 14".
Champion Long Reach "N 8".

For high speed use: Lodge Long Reach "HLN",
Champion Long Reach "NA 8".

The plug insulation and points should be kept clean and free from carbon and the gaps adjusted to .018in.—.020in.
Clean and check every 2,000—3,000 miles.

It is advisable, especially when refitting plugs to the alloy cylinder head of the model "KHA" to well smear the threads with graphite and not to over tighten, otherwise difficulty will be experienced when removing the plug after carbon has been deposited around the thread.

Carburettor. Riders are strongly advised not to alter needlessly the carburettor setting. Keep the carburettor clean and periodically empty sediment and moisture from the float chamber. Note that the size of the main jet controls mixture strength from approximately three-quarter to full throttle, whilst the positioning of the taper needle which is attached to the throttle slide controls the mixture between approximately one-quarter and three-quarter throttle. As the taper needle and needle jet wear, the mixture is richened up over this range, and petrol consumption will increase. This can be compensated for by lowering the needle (i.e., securing in a higher notch); make the adjustment one notch at a time until all adjustment has been taken up, after which both parts must be replaced.

Pilot air screw. This screw regulates the strength of the mixture for "slow running" and for the initial opening of the throttle. The screw controls the suction on the pilot fuel jet by metering the amount of air that mixes for the fuel. With the engine warm and the twist grip turned to the shut position adjust the throttle stop screw in conjunction with the pilot air screw to get good slow running.

The following are standard carburettor settings:—

Model	Jet size	Throttle size	Needle position notches from top
K.H. and K.H.A.	150	6/3	3rd

For altitudes above 5,000 feet or for use with alcohol or similar fuels special jet sizes should be ordered.

Air Filter. Air filters can be supplied to order, and we strongly advise their use in countries where dusty conditions are prevalent. The filter can be readily dismantled for cleaning, which should be done frequently to avoid clogging. If kept clean no alteration is necessary to the standard carburettor setting when an air filter is fitted, but if it is allowed to become partly clogged the fuel consumption will increase and engine performance will deteriorate.

For further details of carburettor tuning see the "Amal" hints and tips leaflet.

ENGINE SHAFT SHOCK ABSORBER

(See Exploded View).

The shock absorber assembly is not adjustable, and providing the outer locking sleeve is securely tightened no trouble will be experienced except perhaps after lengthy service the spring may weaken or fracture.

The correct order of assembly for the shock absorber is as follows:—

- (a) Splined Driving Sleeve with Oil Seal next Bearing.
- (b) Engine Sprocket.
- (c) Sliding Member.
- (d) Spring.
- (e) Spring Retaining Plate.
- (f) Sleeve Locking Nut.

THE MAGNETO

The magneto is fitted with special cobalt steel magnets and to prevent damage to the armature in the event of the external high tension circuit being interrupted, the unit is provided with safety spark gaps, the earth electrodes of which are two screws, one on the top and one on the underside of the main housing.

These two screws must never be removed except when dismantling, and then it will be necessary in order to withdraw the armature from the housing.

AUTOMATIC TIMING DEVICE

This device is incorporated with the magneto driving gear and does not require any attention or adjustment.

It automatically provides the required magneto timing, in relation to the engine, for all conditions of running, and so considerably improves the performance of the motor-cycle. When stationary, and at idling speeds, the device automatically returns to the retarded position, advancing as the speed of the engine increases.

Should for any reason, it be necessary to remove the magneto, the magneto gear and timing device can be removed by undoing the self-extracting nut on the end of the magneto armature spindle. After the nut loosens, it will almost immediately tighten again, and it is then that it commences to withdraw the gear and timing device from the tapered magneto spindle.

Do not in any circumstances, take the automatic timing device to pieces or attempt to remove it from the gear wheel.

For details of magneto timing refer to page 24.

ATTENTION IN SERVICE

LUBRICATION

The magneto armature runs on ball bearings, which are packed with grease before the magneto leaves the Works. This lubricant should not require renewal for a considerable period.

CONTACT-BREAKER

It is of the utmost importance that the points on the contact-breaker should be kept absolutely free from oil, because any oil on the contacts will become oxidized and prevent good electrical contact between the points when closed. Failure to observe this may result in a considerable reduction in the current from the magneto.

The magneto is intended to operate with a gap of approximately 0.012 inch between the contact points. This gap should be checked occasionally by means of the feeler gauge attached to the small spanner provided with each machine. Do not

unnecessarily re-adjust the contact gap. Great care should be taken to keep the contacts absolutely clean. The points are made slightly convex, and when necessary may be cleaned with a very fine emery cloth, but under no circumstances should they be filed.

The contact-breaker may be removed for cleaning by unscrewing the central hexagon-headed screw and withdrawing the breaker. The contact lever may then be lifted from its bearing bush by first raising and then moving to one side the check spring which is located in the end of the bearing bush. Care should be taken not to distort the contact lever control spring in any way. When replacing the contact lever it is advisable to smear the bearing bush lightly with thin lubricating oil, taking the utmost care to wipe off any surplus oil for the reasons already stated.

COLLECTOR BRUSH

The collector brush moulding should be periodically removed and the surface wiped clean with a cloth moistened with petrol. Before replacing this moulding, insert a corner of a clean cloth in the aperture in the housing so that it bears against the slip-ring track and the flanges, and at the same time turn the engine slowly. This will remove any oil or carbon deposit likely to cause leakage over the slip-ring flanges. On no account must any implement be used to exert undue pressure with the cloth on the slip-ring flanges, as this may cause them to be broken.

See that the cleaned parts are dry and that the petrol vapour is expelled before restoring the magneto to service.

DISMANTLING THE MAGNETO

Total dismantling of the magneto should be rarely necessary, but in case this should be required, instructions are given below, and the following procedure should be closely followed :—

1. The contact-breaker cover should be removed after rotating the securing spring on its pillar.
2. The hexagon-headed screw in the centre of the contact-breaker should then be unscrewed, allowing the contact-breaker to be withdrawn bodily.

3. The collector moulding should next be removed, and also the two safety spark gap screws.

It is important to note that the collector moulding and also the safety spark gap screws must be removed before any attempt is made to withdraw the armature from the housing. Failure to observe this will result in damage to the collector moulding and slip-ring.

4. The contact end-plate may now be removed by unscrewing the fixing screws and the contact-breaker cover spring pillar.

5. The armature may then be withdrawn from the housing.

NOTE.—If the armature is actually withdrawn from the housing it will be necessary to re-magnetize the magnet after replacing the armature.

When re-assembling the magneto, great care should be taken to ensure that the key on the contact-breaker base engages with the slot in the armature end-plate.

LOCATION OF FAULTS

If the engine is firing irregularly, due to faulty ignition, the investigator should first of all satisfy himself that the fault does not lie in the plug, the sparking gap of which should be set at 0.018 in.

Faulty ignition may result if the high tension cable becomes detached, loose, broken, or earthed, so that a careful examination of the connections and cable should be made. If sparking persistently occurs at the safety gap, it is an indication that there is a break in the external high tension circuit.

Irregular firing may result from defective operation of the contact-breaker. To determine whether this is the case remove the contact-breaker cover and make sure that the contact-breaker fixing screw is securely tightened. Attention should also be given to the contacts; the adjustable one should be securely locked in position. The gap should be checked and if necessary, adjusted to the thickness of the feeler gauge attached to the spanner supplied with the machine.

THE DYNAMO

The dynamo is a LUCAS TYPE E.3H, 6-volt separate unit, and a short maintenance treatise will also be found in the maker's handbook.

TRANSMISSION

BURMAN GEARBOX AND CLUTCH ASSEMBLY TYPE "BA"

The following information is relative to the Burman "BA" type Gearbox fitted to all "KH" models previous to Engine Serial No. TE.1025—1952.

On and after Engine No. TE.1025—1952-53 the Burman Gearbox type GB.6 was fitted. All "KHA" models are fitted with the GB.6 type Gearbox. See Page 43.

1. CLUTCH ADJUSTMENT (Fig. 11)

Adjustment to the clutch plates and springs is rarely necessary, and the spring plate tension is correct when the ends of the springs are just visible when looking across the face of the spring plate. This gives ample pressure to ensure efficient clutch grip. If the screws are tightened more it makes clutch withdrawal unnecessarily heavy. After adjusting the clutch, see that the spring plate lifts equally; if not, the nuts should be eased off on the low side or tightened on the high side until it does.

The cable adjuster on the gearbox should be set to keep the operating lever in such a position that the control cable is subjected to the minimum of bending; then adjust the plunger screw through the operating lever to give 1/64th-in. clearance between the two thrust points on the lever and the face of the plunger which slides through the gearbox cover. To vary the clearance, push in the top end of the operating lever (thus withdrawing the clutch), and slip off the control inner wire. Let the lever fall down and rotate the screw through the plunger clockwise to decrease clearance and vice-versa. Replace the cable and check the clearance. The adjustment cannot unscrew in operation, as the head of the screw and flats formed on the plunger will only slide through, and not rotate in, the slotted operating lever.

To remove the rubber protecting cover, pull the top end down along the operating lever, after which the lever can be pushed in and the cable freed.

If the plunger is pulled out, take care not to lose the ball which comes between the ends of the clutch rod and the adjusting screw.

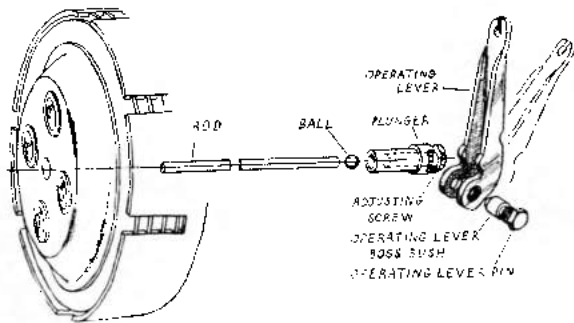

Fig. 11. Clutch Cable and Rod Adjustment.
"BA" Gearbox.

DESCRIPTION OF PARTS

53. Clutch Operating Rod.
54. Clutch Operating Plunger.
55. Clutch Operating Lever.
62. Clutch Spring Adjusting Nut.
63. Clutch Spring.
64. Clutch Spring Cup.
65. Clutch Spring Plate.
66. Clutch Plain Plate.
67. Clutch Plate fitted Cork Inserts.
68. Cork Insert.
69. Clutch Spring Stud.
70. Clutch Centre.
71. Chain Wheel Centre Bolt.
72. Chain Wheel Centre Tab Washer.
73. Clutch Case.
74. Clutch Case Band.
75. Mainshaft Nut—Clutch End.
76. Mainshaft Nut Plain Washer.
77. Thrust Washer—Keyed.
78. Needle Roller cage.
79. Thrust Washer—Plain.
80. Needle Rollers.
81. Clutch Chain Wheel.
82. Mainshaft Nut Lock Washer.

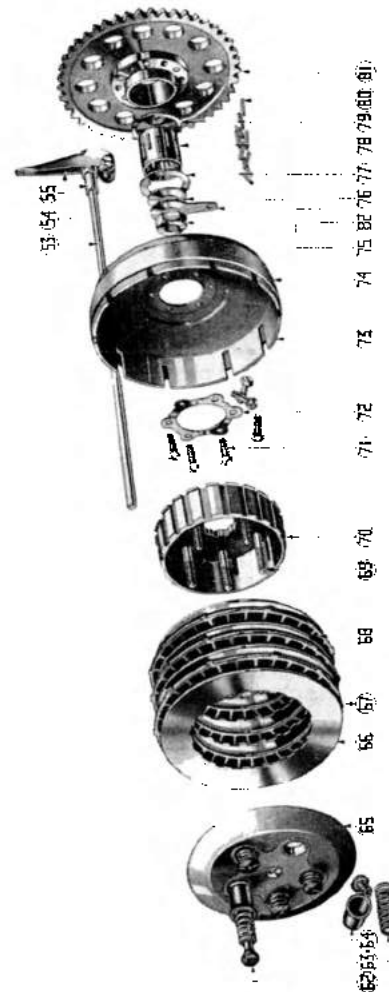

Fig. 12. Exploded View of Clutch Assembly for "BA" Type Gearbox.

2. CLUTCH PLATES—REMOVAL AND RE-ASSEMBLY

Remove the clutch dome held by four screws, and then undo the five spring retaining nuts projecting through the spring plate, when the clutch plates can be withdrawn. Care should be taken to re-assemble them in the correct order. The first plate to be put in is a plain plate then a cork insert plate and a plain plate alternately, finishing with a plain plate. The heads of the spring retaining nuts should stand slightly proud of the spring plate (see adjustment, page 31).

3. REMOVAL OF THE CLUTCH BODY AND SPROCKET (See Fig 11)

Remove the clutch plates, undo the securing nut on the end of the mainshaft, and pull off the clutch centre, which is splined on the mainshaft. This leaves the clutch sprocket and outer clutch housing (carried on a needle roller bearing) in position on the shaft. To remove these parts, knock back the edges of the ring tab washer locking the six set bolts in the centre of the housing and take out the bolts; the outer housing is now free. To remove the sprocket, sleeve and needle roller bearing can be slipped off the shaft. Note that the rollers are not held in the cage and can therefore drop out when the sleeve is pulled off the shaft. When refitting these parts stick the rollers into the cage with a little grease. A plain washer fits *behind* the roller race and a tongued washer *outside* the race, next the clutch sprocket. Sometimes a tab washer is also fitted *behind* the outer clutch housing. This is used simply as a packing washer to increase the clearance between the clutch housing and the chain case.

When reassembling be absolutely sure that the six set bolts are screwed right home and that they are locked in position by the circular tab washer. Also do up the mainshaft nut, securing the clutch centre, dead tight, and do not forget to refit the special lock washer behind the nut.

THE GEARBOX "BA" TYPE

1. REMOVING GEARBOX FROM FRAME

Remove the near side footrest, brake pedal and rod.

Remove clutch dome, dismantle clutch and remove clutch centre and clutch case.

Take off outer half of primary chain case. Note the small round paper joint washer between the two halves of the case, at the footrest boss.

Disconnect primary chain and draw clutch sprocket off mainshaft, taking care not to lose rollers out of bronze cage.

Disconnect clutch cable and push out clutch operating rod with plunger and adjuster towards the offside, in order to prevent loss or damage.

Remove gearbox clamp bolt (top— $\frac{1}{2}$ in. dia.) towards the offside and loosen gearbox adjuster. Slacken the tie bolts through the rear engine plates and seat tube lugs and also through the plates and crankcase lugs to give the gearbox clamping lug some play between the plates.

Remove gearbox pivot bolt at bottom and take out box towards the offside.

2. DISMANTLING THE BOX (See Fig. 13)

First remove the clutch and clutch sprocket assembly, as already described. Next undo the nuts holding the gearbox outer cover and pull away the cover complete with the foot control operating mechanism and kickstart lever. Now unscrew the nut on the end of the mainshaft and pull off the ratchet pinion and sleeve. Undo the nuts holding the inner case and pull this away from the main gearbox casing, taking care not to lose the 12 rollers forming the roller race on the gear operating camshaft. Now unscrew the pawl spring plug at the bottom of the gearbox and take out the pawl spring, after which the entire gear assembly together with camshaft and operating forks can be removed from the gearbox en bloc. It may be found easier if the mainshaft is first pulled out from the clutch end.

The driving gear, ball bearing and rear sprocket are now left in the gearbox case. To remove these, hold the sprocket so that it cannot rotate and undo the large nut securing the sprocket to the driving gear sleeve. Note the special lock-washer fitted behind the nut. The driving gear will push through into the gearbox case whilst the ball bearing can be taken out after removing the bearing gland or oil seal, gland washers, etc. (See Fig. 13 for order of assembly).

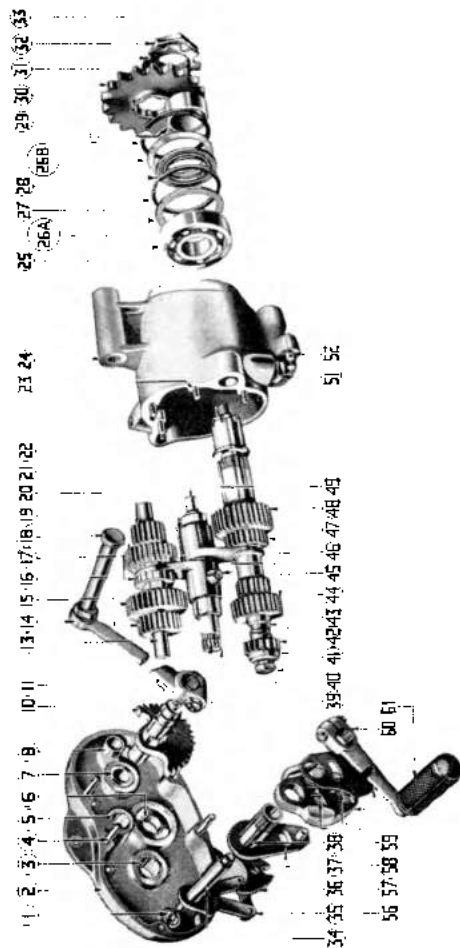

Fig. 13 Exploded view of Gearbox Assembly. (Type "BA")

Note : In order to show all parts clearly the complete assembly has been turned upside down (*i.e.*, the lay-shaft is shown above the mainshaft instead of in its normal position below the mainshaft, etc).

DESCRIPTION OF PARTS

(See Fig. 13)

- | | |
|-------------------------------------|---|
| 1. Sector Spindle Bush. | 31. Driving Sprocket. |
| 2. K.S. Case—Gearbox Case, (inner). | 32. Lock Washer. |
| 3. Camshaft Bush—K.S. Case. | 33. Driving Gear Nut. |
| 4. Gearbox Cover Stud. | 34. Footchange Sector Spindle. |
| 5. Layshaft Spindle Bush. | 35. Gear Sector, Quadrant and Ratchet Assembly. |
| 6. Mainshaft Ball Bearing. | 36. Pawl. |
| 7. K.S. Spindle Bush (Inner) | 37. Control Quadrant. |
| 8. K.S. Stop Peg Rubber. | 38. Ratchet Sleeve. |
| 9. K.S. Quadrant. | 39. Camshaft Rollers. |
| 10. K.S. Spindle | 40. Selector Pinion on Camshaft. |
| 11. Layshaft Spindle. | 41. K.S. Ratchet Nut. |
| 12. K.S. Lever. | 42. K.S. Driving Ratchet. |
| 13. Third Gear—Layshaft. | 43. K.S. Ratchet Pinion |
| 14. First Gear—Layshaft. | 44. K.S. Ratchet Spring. |
| 15. Layshaft Clutch | 45. Third Gear Mainshaft. |
| 16. K.S. Lever Pedal. | 46. Operating Peg (Camshaft). |
| 17. Second Gear—Layshaft. | 47. Mainshaft Sliding Gear. |
| 18. Layshaft Small Gear. | 48. Driving Gear. |
| 19. Operating Fork (Layshaft). | 49. Camshaft. |
| 20. Operating Fork (Mainshaft). | 50. Filler Plug. |
| 21. Gearbox Stud. | 51. Gearbox adjustment Peg. |
| 22. Gearbox Shell. | 52. Main Spring (Footchange) |
| 23. Driving Gear Ball Bearing. | 53. Pawl Spring (Footchange). |
| 24. Gland Washer (Flat). | 54. Spring Box (Footchange). |
| 25. Ditto. | 55. Cover Plate (Footchange). |
| 26. Locating Ring (Split). | 56. Foot Control Lever. |
| 27. Bearing Oil and Grease Seal. | 57. Lever Rubber. |
| 28. Retaining Ring (Split). | |
| 29. Sprocket Spacing Collar. | |

A good workshop method of holding the sprocket is as follows: Procure a scrap mainshaft and grind two flats on the part which carries the clutch roller race. Hold the mainshaft upright, clutch end at the bottom, and grip the two flats in a vice. Next take the sliding gear (mainshaft) and place this on to the shaft with the larger end (second gear pinion) uppermost. If the gearbox shell or case complete with the driving gear still in position is now placed over the shaft, the dogs on the second gear pinion of the sliding gear will engage with the dogs on the driving gear thus securely holding the gear and gearbox driving sprocket whilst the nut is unscrewed.

An alternative method is to hold the sprocket with a length of rear driving chain, but this is not so rigid or convenient as the method described.

If the operating forks are removed from the camshaft, note that the two forks are different, the longer one operating the gear clutch on the layshaft.

3. REASSEMBLING THE BOX (See Fig. 13)

Reassembly is straightforward, but it will be found easiest to make a complete sub-assembly of the layshaft with gears, mainshaft gears (except driving gear which is already in the box) and camshaft and fork assembly, after which the whole assembly can be fed together into the gearbox shell. The mainshaft is then inserted through the driving gear. The rollers for the cam spindle should be held in place with thick grease whilst the kickstarter case is fitted.

When assembling the toothed ratchet of the gear control mechanism with the gear on the end of the camshaft, see that the marked teeth on the two members are assembled together, otherwise the gears will not be in correct register. Whilst it is quite possible to reassemble the foot control mechanism in one complete unit with the end cover, it will probably generally be found simpler to reassemble first the pawl, ratchet operating plate and spring box, after which the outer case and foot control lever can be put back into position.

4. FOOT GEAR CHANGE MECHANISM

This mechanism is very simple and easily operated although at first sight it may appear somewhat complex. The control positions of the foot operated lever are clearly indicated in Fig. 14, and each respective gear when once engaged is locked in a positive position and does not require to be held by the foot pressing on the pedal when the machine is in motion.

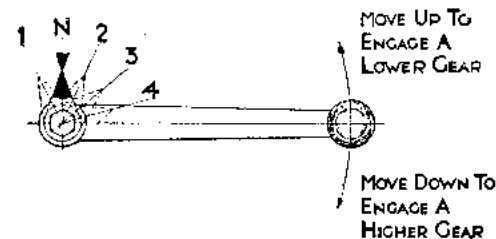

Fig. 14.

The action of the internal mechanism (Fig. 15) is as follows: The footchange lever bush (F.C.L. Bush) is fitted with the rectangular extension inside the gearbox outer cover and is secured by the footchange lever bush bolt (F.C.L.B. Bolt) the plain end of which projects into the spring box between the two main springs. The spring box and control quadrant are carried on the ratchet sleeve; the box, however, is free, whilst the quadrant is fixed on splines. The footchange lever fits on the fine splines at the outer end of the sleeve. The sector and ratchet assembly (riveted together) with toothed quadrant, is positively fixed to the sector spindle which passes through the ratchet sleeve and carries the moveable indicator or pointer on the outer end. The peg "A" firmly fixed in the control quadrant has one end located between the pawl springs in the spring box and the other end located in the slot in the pawl. The pawl is pivoted on the peg "B" which is firmly fixed in the spring box and which passes through a slot in the control quadrant.

When the footchange lever is moved it rotates the ratchet sleeve and the control quadrant which it is splined onto it.

The peg "A" fixed in the control quadrant tips the pawl round the peg "B" until it engages with the ratchet after which continued movement of the control quadrant causes the whole assembly of control quadrant, sector and spring box, etc., to move until one of the flanges on the side of the spring box becomes up against the rectangular extension of the F.C.L. bush. This movement is transferred from the sector and quadrant to the gear on the camshaft and causes rotation of the shaft and selective movement or engagement of any respective gear. As soon as the footchange lever is released the main springs in the spring box return the assembly to the central position and the pawl springs disengage the pawl from the ratchet.

If it has been necessary to dismantle the gear box end cover for any reason always ensure when reassembling that the marked teeth of the footchange pawl and ratchet are meshed together as explained in previous notes under "Reassembling the Gearbox."

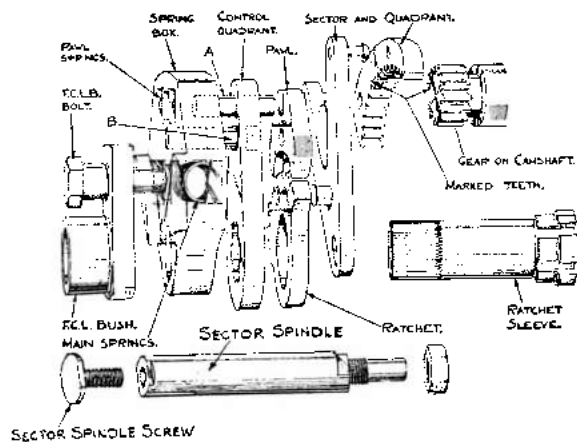

Fig. 15.

After lengthy service it will probably be found necessary to replace the footchange pawl and ratchet due to the engaging leading edges becoming worn down and failing to operate

the full travel of movement necessary to correctly mesh the sliding gears. The symptoms of running with a worn pawl and ratchet will be those of failure to engage a gear or of "jumping out" of gear.

5. KICKSTARTER LEVER RETURN SPRING

The K.S. return spring should have sufficient tension to bring the lever back to the upright position where it should be retained by the spring pressure.

If the spring should weaken, tension must be increased or if the spring is broken it must be replaced. The general procedure is the same in either case.

1. Disconnect clutch cable at gearbox end and loosen offside footrest.
2. Remove footchange lever and pinch bolt through K.S. lever.
3. Remove nuts securing gearbox outer cover.
4. Hold K.S. lever and pull off outer cover complete with kickstarter and footchange mechanism still in position in the cover. Withdraw clutch operating plunger and take care not to lose the steel ball between adjusting screw and clutch operating rod.
5. If the return spring is only insufficiently tensioned proceed as detailed in item 6.

If the spring is broken or has to be replaced pull the kickstarter lever off the splined shaft and push the shaft and starter quadrant out of the cover. Remove the old spring. Take the new spring and remove the binding wire. Hold the quadrant and shaft assembly with the splined end of the shaft towards you and the quadrant hanging downwards. Slip the spring on to the shaft so that the inner end engages with the lowest of the slots next to the quadrant, *i.e.*, slot at 6 o'clock position.

Ensure that the spring is the correct way round. The coils should run clockwise from the centre to the outside of the spring. Push the shaft or K.S. axle through the bush in the outer cover and place the looped outer end of the spring over the peg in the outer cover. Place the

K.S. lever on the spindle and wind up for one and a half to two turns. The actual amount may vary with different springs. Finish up so that the quadrant is in the normal "out of action" position (*i.e.*, below the shaft as at the commencement of fitting the new spring) with the cover held in the normal horizontal position.

Next give a further half turn equivalent to depressing K.S. lever to start the engine. The spring must not close solid but must exert enough tension to return the lever smartly to the normal vertical position.

6. If the spring coils close up solid, unwind the spring, place the inner end one or two slots to the left (clockwise) and refit as described in paragraph 5. If the spring has insufficient tension move the inner end one or two slots to the right (anti-clockwise) and refit.
7. Refit the gear control mechanism into the inner end cover and replace outer cover and bolt up securely. See previous notes "Reassembling the Gearbox."
8. Fit footchange lever, tighten K.S. lever pinch bolt and reassemble clutch withdrawal.

6. LUBRICATION—GEARBOX ("BA" TYPE)

The gearbox incorporates a special lubricant seal next to the driving gear bearing and the main case should be filled with an oil and grease mixture made up on a 50/50 basis, using half good quality engine oil mixed with other half of gear grease.

This gearbox requires "topping" up approximately every 1,000 miles or so with the pressure gun containing the same mixture.

If spare parts for a gearbox are required always quote the series number to enable the Works Service Department to identify the correct model.

Standard Gear Ratios—Model "KH" Fitted with Burman BA type gear box. Specification and Gear Ratios.

	Engine Sprocket	Top	Third	Second	First
SOLO	21.T	5.20	6.65	9.15	13.85
SIDECAR	19.T	5.75	7.40	10.15	15.40
CLUTCH CHAIN WHEEL		44.T
GEARBOX DRIVING SPROCKET		19.T
REAR WHEEL CHAIN SPROCKET		47.T

THE BURMAN GEARBOX, TYPE "GB"

(Refer to Page 31.)

DESCRIPTION

The "GB" gearbox incorporates positive footchange mechanism and four speeds and operation of gear change and kickstarter assemblies are very similar to those of the previous Burman "BA" type.

Location of the gearbox main case in the motor cycle frame is by the same method as adopted on previous models, *i.e.*, being held between the right and left hand rear engine plates. The top fixing lug of the gearbox case is slotted and allows the box to be moved on the lower swivel lug to provide driving chain adjustment.

The clutch is identical to that previously fitted to the "BA" gearbox, but the operating arm or lever is located within the enclosed kickstarter end of the gearbox and adjustment provided by the inclusion of a simple sleeve nut arrangement located in a small cover plate on the outer face of the end cover.

Clutch cable adjustment is by way of a common adjuster and cable stop on top of the gearbox end cover.

The exploded view of the complete gearbox and clutch at rear of book clearly indicates the general arrangement of

the internal gear, kickstarter and footchange assemblies. Reference to the given part numbers in the list will provide a full description of each separate component part. See Page 48.

LUBRICATION

Ordinary engine oil is recommended for lubrication of the complete box and a filler cap and an oil level plug are provided on the kickstarter end casing.

Oil code number or grade S.A.E. 50 to 60 of any recommended brand is suitable (See page 82).

The oil level should be checked every 1,000 miles and "topped up" as necessary.

CLUTCH ADJUSTMENT

Adjustment to the clutch plates and springs is rarely necessary and the spring plate tension is correct when the ends of the springs are just visible when viewed across the face of the spring plate. This setting provides ample pressure to ensure efficient clutch grip. If the clutch adjustment screws are tightened more it makes clutch withdrawal unnecessarily heavy. After adjustment see that the spring plate lifts equally, if not, the adjusting screws should be eased off on the low side or tightened on the high side until the plate is equally lifted.

The clutch operating lever within the kickstarter cover should be set to give up to 3/16 in. clearance or free movement which can be felt for testing after removing the oil filler plug and exposing the lever.

To set the operating lever, loosen the small cover plate held by two screws on the face of the end cover and adjust the sleeve nut which can be turned complete with the plate, until the correct position is found to give the necessary clearance. Finally, take up all unnecessary slack in the control cable by means of the external adjuster but take care not to interfere with the free movement or clearance already given to the internal operating lever. Reference to the fully descriptive exploded view of the gearbox will readily assist operators to identify and adjust the clutch withdrawal assembly.

DISMANTLING THE CLUTCH ASSEMBLY

Clutch Plates

Remove the clutch dome cover held by four screws and then undo the five spring retaining nuts projecting through the end spring plate. A slotted screwdriver is supplied in the tool kit for this purpose. The complete set of clutch plates can now be withdrawn from the housing. If clutch slip has taken place, carefully examine the condition of the cork or fabric inserts and replace with factory exchange plates if necessary. Care should be taken when reassembling to fit the plates in the correct order. The first plate to put in is a plain one then alternately a cork or fabric insert plate and a plain plate, finishing with a plain one. See also "clutch adjustment."

Clutch Body and Sprocket

After removing the clutch plates, undo the securing nut on the end of the mainshaft and pull off the clutch centre which is splined on the mainshaft sleeve. This leaves the clutch sprocket and outer clutch housing (carried on a needle roller bearing) in position on the shaft. To remove these parts, turn back the edges of the ring tab washer locking the six set bolts in the centre of the housing and take out the bolts; the outer housing is now free. To remove the sprocket, take off the outer half of the oilbath case when the sprocket, bearing cage and needle rollers can be slipped off the shaft. Note that the rollers are not held in the cage and can therefore drop out when the cage and sprocket are pulled off the shaft. When refitting these parts secure the needle rollers in the cage with a little grease. A plain washer fits **behind** the roller race and a tongued washer **outside** the race next to the clutch sprocket.

When reassembling be absolutely sure that the six set bolts are screwed right home and that they are locked in position by the circular tab washer. Also ensure that the mainshaft nut securing the clutch centre is tightened fully and the special lock washer is placed behind the nut.

DISMANTLING THE KICKSTARTER CASE END COVER

Removing the K.S. case end cover enables examination to be made of the internal clutch operating lever and

plunger and also exposes the complete K.S. and footchange mechanism as well as the speedometer spiral gear drive.

Before removing the end cover take out the oil drain plug and allow all oil to drain off.

Release the clutch cable adjuster sufficiently to allow the inner wire and nipple to be detached from the inner operating lever.

Next take off the nut securing the gear indicator cap and small coil spring enclosed on the end of the footchange cam barrel spindle. Then unscrew the six cheese headed screws which secure the outer K.S. cover to the inner K.S. case, noting carefully the position of the three different lengths of screws used.

Next draw the cover forward approximately 1.2 in. taking care to hold securely the K.S. crank and pedal in the vertical position.

Tie the K.S. crank to the footchange lever in order to prevent the K.S. spring from unwinding.

The K.S. end cover can now be fully removed complete with K.S. quadrant and spring and also part of the footchange operating assembly.

Note the position of the main RETURN SPRING for the footchange control quadrant. This is the large "U" shaped flat steel spring working together with the cam cylinder.

After fitting any necessary replacement parts and cleansing, the end cover can be replaced by reversing the procedure, taking care to replace the paper joint washer and tightening all screws before refilling the case with oil. Be sure to replace correctly the small coil spring and gear indicator cap and nut.

DISMANTLING THE KICKSTARTER CASE OR BACK PLATE

After removing the K.S. outer end cover, take off the mainshaft end nut, K.S. driving ratchet and pinion and the small coil spring and sleeve for pinion.

Next dismantle the gear selector spindle split pins, and take out the footchange cam cylinder together with the spring plunger, which it will be noticed makes contact with the various indentations on the face of the cylinder. Take out the clutch operating plunger and rod, noting the method

of engagement between the plunger and the operating lever which will still be attached to the K.S. case outer cover. Also note the position of the small steel ball between clutch rod and plunger.

Remove the four cheese headed screws securing the inner K.S. case to the main gearbox shell, noting the position of the two different lengths of screws, and withdraw the case, leaving the internal gear assembly, etc., in position in the main housing or shell.

It is possible to remove the K.S. rear half case complete with the internal gear assembly, selector forks, etc., all left in position, by taking off the complete clutch as previously described but also removing the splined driving sleeve fitted to the clutch end of the mainshaft.

Without dismantling the K.S. ratchet pinion assembly the four securing screws are taken out and the rear half case can be pulled away with gear assembly attached. This method is the most satisfactory way of making a close up examination of the gear assembly.

Reference to the exploded view should be made when dismantling and reassembling and the correct order of gear assembly, part numbers and titles, carefully noted. When refitting the footchange cam assembly, place in position the ball ended plunger and small coil spring so that the ball end engages with any one of the indentations on the rear face of the cam cylinder. Make quite certain that the paper joint washer is replaced between the K.S. case and the main shell and that the four securing screws are well tightened.

FINAL DISMANTLING

After dismantling the K.S. cover and case with the gear assembly attached as previously described, it will be noticed that the main driving gear ball bearing, rear sprocket and oil seal, will be left in position in the gearbox shell or main case. To remove these, secure the sprocket to prevent rotation and unscrew the large nut locking the sprocket to the driving gear sleeve. Note the special lock washer fitted behind the nut and also the order of assembly of the ball bearing, oil seal and retaining washers.

The driving gear will now push through into the gearbox case, and the ball bearing, which is a press fit in the shell housing, can be driven out after removing the gland oil seal, etc.

Reference should be made to the exploded view when reassembling.

GEAR RATIOS

Gearbox Code Number: "GB" 6

CLOSE—STANDARD

Engine Driving Sprocket	First	Second	Third	Top
SOLO 21T	13.72	8.81	6.77	5.18
SIDECAR 19T	15.15	9.72	7.50	5.72

GEARBOX and REAR WHEEL SPROCKETS are standard throughout the complete range and cannot be altered.

GB GEARBOX AND CLUTCH ASSEMBLY PARTS

(See exploded view at rear of book)

Part Nos.	Description	No. Per Set
3600-52	Gearbox shell only	1
3602-52	Gearbox joint washer	1
3610-52	Kickstarter case	1
3611-52	Kickstarter case joint washer	1
3620-52	Kickstarter case cover	1
3623-52	Kickstarter case cover locating piece	1
3626-52	Mainshaft nut (k/s end)	1
3176-33	Mainshaft bearing	1
3628-52	Bearing retaining ring for mainshaft bearing	1
3630-52	Mainshaft	1
3631-52	Driving sprocket, $\frac{3}{8}'' \times \frac{1}{8}''$, 19.T	1
3632-52	Sprocket spacing collar	1
3095-33	Driving gear bearing	1
3634-52	Bearing retaining ring (Split)	1
3635-52	Driving gear oil seal	1
3636-52	Driving gear oil seal housing	1
3089-33	Driving gear nut	1
3091-33	Driving gear nut lock washer	1
3637-52	Driving gear bush	set of 2
3638-52	Driving gear with bush, 28.T	1
3641-52	First gear mainshaft, 17.T	1
3642-52	Second gear mainshaft, 22.T	1
3643-52	Third gear mainshaft, 25.T	1
3644-52	Third gear mainshaft bush	1
3648-52	First gear layshaft, 29.T	1
3649-52	Second gear layshaft, 24.T	1

3650-52	Second gear layshaft bush	1
3652-52	Third gear layshaft, 21.T	1
3653-52	First gear layshaft bush	1
3656-52	Layshaft pinion, 18.T	1
3657-52	Layshaft	1
3658-52	Layshaft bush (clutch end)	1
3659-52	Layshaft bush (k/s end)	1
3660-52	Layshaft bush dowel	2
3661-52	Layshaft cover washer	1
3663-52	Speedometer spindle	1
3664-52	Speedometer spindle bush	1
3665-52	Speedometer thrust washer	1
3160-31	Speedometer location button	1
3666-52	Speedometer spindle bush oil seal	1
3164-31	Speedometer spindle bush grub screw	1
3242-31	Gearbox filler plug	1
3670-52	Gearbox drain plug washer	1
3669-52	Gearbox drain plug	1
3671-52	Gearbox and k/s case dowel	1
3676-52	Screw, k/s cover to k/s case	2
3677-52	Screw, k/s case to gearbox	2
3678-52	Screw, k/s case to gearbox and k/s cover to k/s case	4
3679-52	Screw, k/s cover to gearbox	2
3682-52	Gearbox adjuster pivot pin	1
3342-52	Oil level plug	1
3687-52	Oil level plug washer	1
3068-50	Mainshaft nut (clutch end)	1
3070-50	Mainshaft nut lockwasher (clutch end)	1
3675-52	Dowel, k/s case cover locating piece	2
3680-52	Driving ratchet	1
3191-33	Ratchet pinion	1
3196-33	Ratchet pinion spring	1
3683-52	Ratchet pinion bush	1
3325-31	Kickstarter quadrant	1
3686-52	Kickstarter quadrant spindle	1
3688-52	Kickstarter spindle bush (inner)	1
3689-52	Kickstarter spindle bush (outer)	1
3335-48	Kickstarter spring	1
3690-52	Kickstarter spring pin	1
3696-52	Kickstarter lever	1
3305-31	Kickstarter lever pedal	1
3310-37	Kickstarter lever pinch bolt	1
3698-52	Kickstarter lever pinch bolt nut	1
3699-52	Kickstarter spindle oil seal	1
3701-52	Kickstarter lever bolt washer	1
3705-52	Cam assembly	1
3707-52	Cam plunger	1
3709-52	Cam plunger spring	1
3711-52	Cam spindle bush (inner)	1
3713-52	Cam spindle nut, retaining indicator	1

3716-52	Quadrant and drive peg for control spindle	1
3718-52	Quadrant spindle	1
3720-52	Quadrant spindle bush (inner)	1
3723-52	Quadrant spindle bush (outer)	1
3725-52	Quadrant spindle cover washer	1
3728-52	Main return spring for control quadrant	1
3733-52	Selector fork	2
3736-52	Selector fork spindle	2
3738-52	Selector spindle cover washer	2
3739-52	Selector spindle peg	4
3741-52	Selector spindle cotter pin	4
3743-52	Selector spindle oil seal	1
3746-52	Return spring (secondary) (coil)	1
3750-52	Footchange lever	1
3514-33	Footchange lever bolt	1
3516-33	Footchange lever bolt nut	1
3752-52	Footchange lever bolt nut washer	1
3508-33	Footchange lever rubber	1
3754-52	Footchange lever rubber fixing pin	1
3756-52	Footchange indicator	1
3758-52	Footchange indicator oil seal	1
3760-52	Cam spindle bush (outer)	1
3763-52	Indicator oil seal spring	1
3766-52	Mainshaft sleeve	1
3770-52C	Clutch operating lever	1
3783-52	Clutch operating lever adjusting sleeve	1
3785-52	Adjusting sleeve cap	2
3788-52	Adjusting sleeve cap screw	1
3790-52	Clutch operating plunger	1
3794-52	Clutch operating plunger ball, $\frac{3}{16}$ "	1

Clutch Parts

3350-36	Clutch case (three plate)	1
3355-48	Clutch centre (three plate)	1
3360-36	Clutch cork plate fitted cork inserts	3
3365-36	Clutch corks	4
3370-36	Clutch plain plate	1
3380-36	Chainwheel ($\frac{1}{2}$ " \times .305 \times 44.T)	1
3388-41	Chainwheel set pin lock washer	1
3391-36	Chainwheel set pin	6
3394-36	Thrust washer (inner)	1
3397-36	Thrust washer (outer)	1
3400-41	Clutch spring plate	1
3402-52	Clutch spring plate thrust cup	1
3495-36	Clutch spring	5
3410-31	Clutch spring cup	5
3413-31	Clutch spring adjusting nut	5
3417-36	Clutch spring stud (3 plate)	5
3420-37	Roller cage	1
3423-36	Needle rollers	set of 12
3430-52	Clutch operating rod	1

1. PRIMARY CHAIN ($\frac{1}{2}$ in. \times .305 \times 80 or 81 PITCHES)

Chain adjustment is made by swinging the gearbox, which is pivot mounted, back or forward as required. Slack off the pivot bolt which is below the gearbox and which passes through the two lugs on the cradle tubes; similarly slack off the clamp bolt passing through the engine plates above the gearbox. At the top rear extremity of the offside engine plate will be found the draw bolt adjuster; rotating nut on the draw bolt swings the box about the pivot bolt, varying the chain tension. Adjust until the primary chain has approximately $\frac{3}{8}$ in. up and down movement midway between the sprockets at the tightest point. Retighten clamp bolt and pivot bolt.

If the drawbolt nut does not turn easily, do not force it or the lug on the gearbox may be broken. Ascertain why the box is not moving; probably the bolts are not properly free or the chain may be already too tight.

2. REAR CHAIN ($\frac{3}{8}$ in. \times $\frac{3}{8}$ in. \times 95 PITCHES)

The spring clip is fitted on the inner side of the chain, in order to prevent it touching the back of the primary chain case and possibly becoming displaced. It is quite accessible through the rear wheel spokes. The open end of the spring clip must always *follow* the closed end when the chain is running in the normal direction.

To adjust the chain when a rigid frame is fitted, slack off the two rear wheel spindle nuts E (Fig. 17) and loosen the nut securing the brake anchor bar to the brake plate; then adjust by rotating the screw adjusters K; turn each adjuster by an equal amount. The chain should have approximately $\frac{3}{8}$ in. movement in the tightest point midway between the sprockets. After making the adjustment, tighten up the spindle nuts, the locknuts on the adjusting screws and the brake anchor bar nut. Adjust the rear brake if necessary: see brake adjustment, P. 54. See also P. 71 for adjustment with spring frame.

3. CHAIN LUBRICATION

The primary chain is lubricated by dipping into the oil in the case. Maintain the oil level up to the "Oil Level Plug"

but do not overfill or the oil may be thrown out of the case where the gearbox mainshaft enters. The oil level is *not* maintained by the engine lubrication system. No drain plug is fitted and if it is desired to drain off the oil, the outer half of the chaincase must be removed.

Rear chain lubrication is carried out by means of a needle valve in the primary chaincase (just behind the clutch dome) which controls an overflow to the rear chain; this overflow only works when the engine is running. Obtain the correct setting by trial on the road; turn clockwise to decrease the supply and vice versa.

Periodically the exposed rear driving chain should be removed and thoroughly cleaned with paraffin and then dipped in a grease and graphite mixture well warmed. After cooling the excess mixture should be wiped off and the sprockets cleaned before replacing. All spring clip fasteners must be fitted with the closed end facing forward when the chains are running in the correct direction.

FIXED REAR WHEEL AND BRAKE

(RIGID FRAME)

1. REMOVAL OF WHEEL

Support machine on rear stand.

Remove wing nut on brake rod.

Disconnect chain.

Uncouple front end of brake anchor bar.

Slacken spindle nuts.

Release the domed nuts securing the forked ends of the mudguard stays and slacken by one or two turns the pins securing the mudguard front bridge or brackets.

The complete rear guard can then be pivoted upwards.

2. REMOVAL OF BRAKE

After removing wheel undo brake plate locknut and remove brake plate complete with shoes. Pull off shoes. Lightly grease:—

Brake cam spindle.

Fulcrum adjustment wedge and spindles.

Examine the brake linings for wear and, if necessary fit new linings or replacement shoes and linings. If new linings

are fitted see that they are riveted down so that they lie in close contact with the shoe. Also see that the rivet heads are countersunk in the lining and that the foot of the rivet is carefully punched over.

3. REMOVAL OF BEARINGS

First take out the wheel and remove the brake plate as described in items 1 and 2.

Screw off the two thin adjusting and locking nuts (G and H, Fig. 16) and tap out the spindle towards the brake drum side. Prise off the two dirt excluding covers; these will probably be damaged and therefore require replacement. The inner races, rollers and cages of the taper roller bearings will drop out complete.

The outer races are pressed into the hub and should not be removed needlessly. Each race bears against an abutment washer in the hub tube. Remove the race by driving out with a drift placed through the hub and bearing up against the back of the abutment washer.

Examine the track of the outer race. The inner race track cannot easily be seen as it is masked by the rollers and roller cage; however, wash in petrol, examine as well as possible, and also examine the taper rollers and the cage. If any parts are seriously worn or damaged replace the whole bearing assembly, *i.e.*, outer race, together with inner race, rollers and cage.

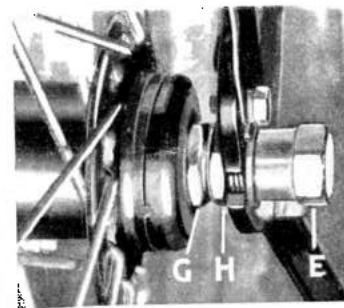

Fig. 16 Rear Wheel Bearing Adjustment.

4. WHEEL BEARING ADJUSTMENTS. (See Fig. 16)

When the wheel has been refitted to the frame, slacken the outer spindle nut E on side opposite brake drum; hold inner cone adjusting nut G and loosen outer locknut H. Adjust inner nut, and then, still holding this inner nut, tighten the locknut and the outer spindle nut. When the bearing is correctly adjusted there must be just the slightest slack as measured at the rim.

5. BRAKE ADJUSTMENT. (See Fig. 17)

All normal brake adjustment must be made by rotating the square-ended fulcrum screw situated in the brake plate diametrically opposite the brake lever bearing. Turn clockwise to compensate for wear. The hand adjuster on the rear end of the brake rod must be slacked off whilst the fulcrum adjustment is made. When the fulcrum spindle will

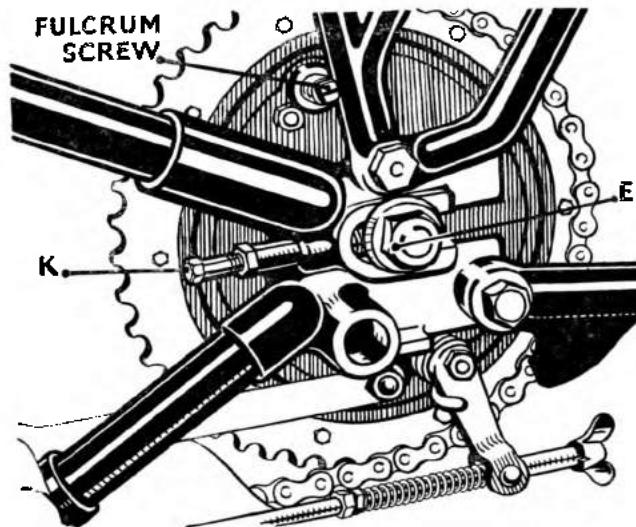

Fig. 17 Rear Brake Fulcrum and Chain Adjustment
(Fixed Rear Wheel)
Fixed Rear Wheel and Chain Adjustment
(Spring Frame) See Page 71.

turn no further, re-tighten the hand adjusting nut until the brake pedal has only a trace of idle movement. **Always adjust the rear brake by means of the fulcrum adjuster. The thumb screw on the brake rod must only be used to compensate for rear chain adjustment. This is important if good braking and even wear on the brake linings is to be obtained.**

6. BEARING LUBRICATION

The hub should be packed with grease during assembly or grease may be pumped in via the grease nipple after the bearings have been assembled, but before the brake plate is fitted. Spin the wheel a few times, holding by the spindle, and wipe off any surplus which works out past the bearings.

FRONT WHEEL

(See Figs, 19, 20 and 21, Telescopic Fork Assembly)

1. REMOVING FRONT WHEEL

With the machine on front and rear stands, proceed in the following order :—

Wipe all dirt off the piece of exposed spindle "A" between the wheel and the fork tube lug on the side opposite the brake. Unscrew the spindle nut "B" on the brake side and the bolt "C" securing the brake plate to the fork. Slightly rotate the brake plate so that the cable nipple "D" can be readily disconnected from the brake lever. Then loosen the pinch bolt "E" on the other fork tube, and using a tommy bar in the hole in the wheel spindle "F" pull the spindle straight out, giving it a slight twist in either direction. The wheel is then free. Do not let dirt get into the spindle holes—plug them with small pieces of clean rag.

2. REMOVING BRAKE

After removing the wheel the brake plate can be taken off complete with operating cam, brake shoes and springs in position. If the brake shoes are removed for re-lining, lightly re-grease the brake cam and fulcrum adjustment before refitting the brake plate, and refer to para 5 re notes on front brake adjustment.



Fig. 18. Removing Front Wheel

3. REMOVING HUB BALL BEARINGS AND REPLACING

The front hub spindle is carried on two single journal ball bearings pressed into the hub centre. If it is necessary at any time to remove the bearings, proceed as follows; First unscrew the brass locking ring (right-hand thread) using the special plug spanner from the tool kit, and carefully take out the grease retaining rubber washer which covers the bearing.

This refers to the left-hand side of the hub. Next turn to the right-hand or brake side and take off with the point of a screwdriver the metal dust cover, then the brass locking ring and grease retaining rubber washer. Next remove the thick bearing abutment steel washer and both ball bearings can be punched out from opposing sides using a suitable drift or punch through the hub centre. Note the steel distance bush fitted to the brake side bearing only.

4. REPLACING WHEEL

Proceeding in the following order: Wipe the spindle absolutely clean and start it in the end from which it came out, then lift the wheel into position and slide the spindle right through. Twist the brake plate round so that the lug "G" will receive the anchor bolt "C". Connect the cable nipple "D" with the brake lever and screw the anchor bolt "C" home but not quite tight. Next screw on the wheel spindle nut "B" and tighten, then finally tighten the anchor bolt "C." The last operation is to tighten the pinch bolt "E" on the other fork tube, but before doing this, work the fork up and down once or twice by pressing on the handlebars to allow the end lug to find its natural position along the spindle as shown at "H". Tighten the pinch bolt "E" in this position, taking care not to move the lug along the spindle while doing so.

5. FRONT BRAKE ADJUSTMENT

Adjustment of the cable stop "J" is only for taking up initial cable stretch. Adjustment for brake lining wear is made by turning the square-ended cam "K" attached to the brake-plate similar to the rear brake. Turn one or more clicks in a clockwise direction. Occasionally oil the brake cable, nipple and cam spindle.

6. FRONT HUB BEARING LUBRICATION

Once or twice a year add about a teaspoonful of thin grease to the hub bearings. This can be done by pushing it through the spindle hole—either side—with the finger. A grease nipple is not fitted. The job is most conveniently done when the wheel has to be removed for some other purpose. The bearings do not require adjustment.

WHEEL ALIGNMENT

Procure a plain board about 6ft. long, 3in. wide and $\frac{3}{4}$ in. thick see that one edge is perfectly straight. With the machine on the stand, place the straight edge of the board alongside the two wheels so that it touches each wheel. Turn the handlebars if necessary so that the front wheel touches the edge of the board at two points. If the wheels are in perfect alignment the board will also touch the rear wheel at two points. If it does not touch in this manner, slack off the rear wheel spindle nuts and turn the chain adjusters (see Fig. 17) until the wheel touches the board at two points. The handlebars may require turning very slightly, to adjust the position of the front wheel to correspond with the new position of the rear wheel.

When the two wheels are in proper alignment, the straight edge of the board will touch each wheel at two points.

ARIEL TELESCOPIC FORK WITH HYDRAULIC CONTROL

To get the best results and greatest satisfaction from this fork, we strongly recommend all owners carefully to read these notes on maintenance, because they describe exactly what should be done and how to do it properly. The more difficult work will naturally be done by one of our Dealers who is fully conversant with the repair aspect of the job, but ordinary maintenance can easily be done by the owner himself.

As explained in our sales literature, the fork requires no lubrication or adjustment, so please do not tamper with it. Just see that the nuts are kept tight and front brake properly adjusted as it wears.

Oil Recommendations for Hydraulic Fork.

The forks are filled with oil before leaving the factory to a level of 17 to 18 inches below the top face of the top bracket, measured when the motor cycle is standing unloaded in an upright position. They do not require "topping up."

WAKEFIELDS	Castrol XL
ESSO	Essolube 30
B.P. ENERGOL	Energol S.A.E. 30
SHELL	X-100/30
VACUUM	Mobiloil A

EXPLODED VIEW OF
TELESCOPIC FORK
ASSEMBLY WITH
HYDRAULIC CONTROL



Fig. 19

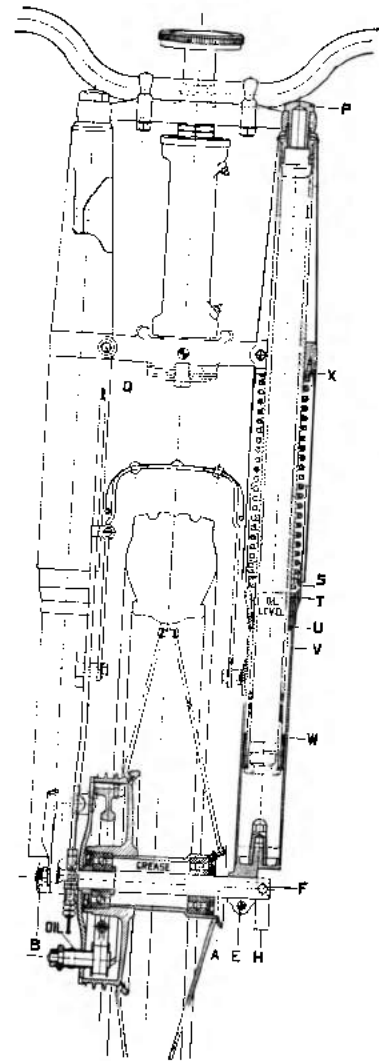
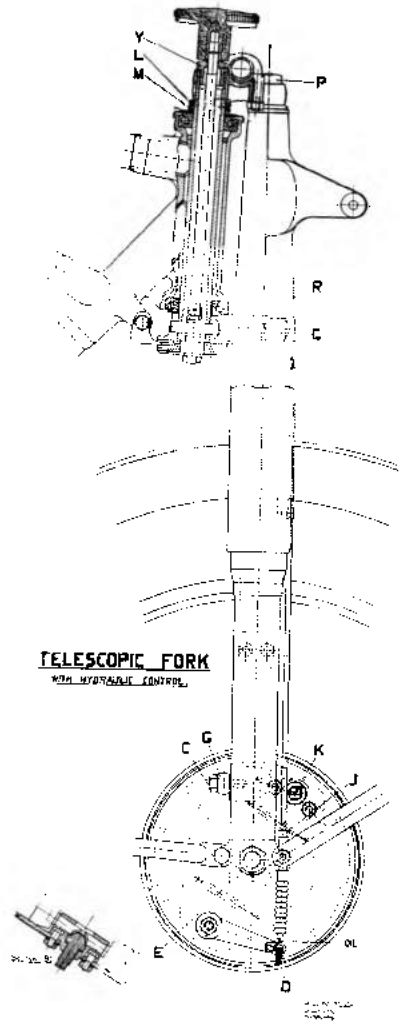

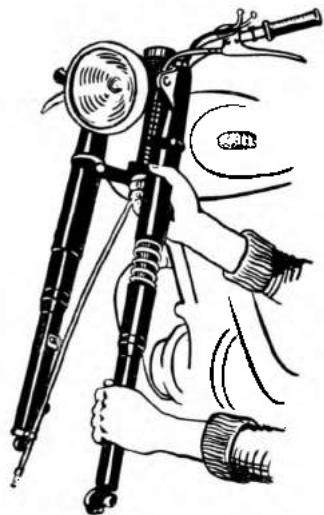

Fig. 22.
Removing sliding tube and mainshaft after unscrewing "Top Plug".



Fig. 23.
Taking off Coil Spring.

Export.

In countries where extremely cold conditions prevail Mobiloil Arctic, etc., will be used instead of the heavier oils.

Passenger or Commercial Sidecar.

When the machine is ordered for use with a sidecar, stronger fork springs will be fitted. Do not fit a sidecar to a machine

not fitted with these strong springs and do not use a machine fitted with strong springs for solo work or the maximum comfort will not be obtained.

Fig. 24. Removing sleeve carrying oil seal with special service tool.

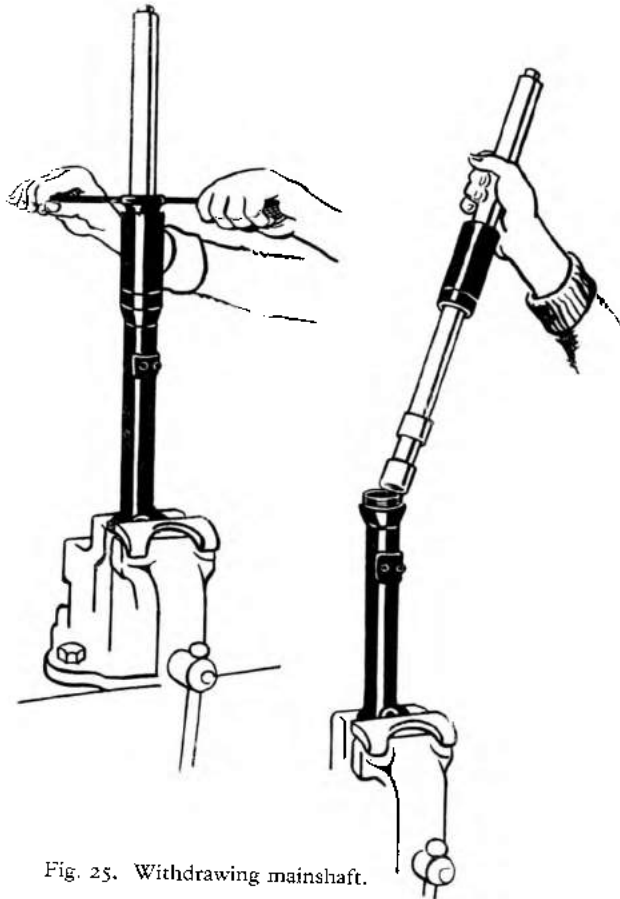

Fig. 25. Withdrawing mainshaft.

Completely Dismantling the fork

It may be necessary to dismantle the fork as the result of an accident or other cause, in which case proceed as follows:—

Support the front of the machine on a box under the engine so that the wheel is clear of the ground. Remove the front stand, mudguard and cable clip, but not the headlamp. Remove front wheel as previously described. Unscrew the hexagon plug "P" at the top of the fork, then loosen the pinch screw "Q" in the crown with the special hexagon spanner provided and each fork tube complete can be pulled out from below. See Figs. 20, 21 and 22. If it is too tight to slide, wedge a screwdriver in the split of the crown "R". Replace hexagon plug "P" to prevent oil escaping. To continue dismantling take off the spring, Fig. 23, and unscrew the sleeve "S" carrying the oil seal with a special spanner supplied to ARIEL Dealers, Fig. 24. Next remove the circlip "T" retaining the top bush "U" and whilst holding the main fork tube in a soft jaw vice, knock gently with a mallet on the end of the sliding tube "V" so that the bottom bush "W" will force the top bush "U" out. The main tube can be withdrawn complete with bottom bush, Fig. 25. The latter is secured with a sleeve nut. The bottom cover can be removed by undoing three screws "X" with a long screwdriver and the top cover by loosening the one nut "Y" below the steering damper knob. Figs. 20 and 21.

To Reassemble

If the covers have been removed replace these first, but do not *finally* tighten the top nut "Y" below the steering damper knob. Pass the oil seal and housing "S" over the main tube and also the top bush "U" then insert the bottom bush "W" in the sliding tube "V." Hold the main tube in a soft jaw vice and place a split sleeve supplied to ARIEL Dealers over the tube so that it touches the end of the vice jaws on the side and the top bush "U" on the other. Knock gently on the end of the sliding tube "V" until the bush is forced home.

Fit the circlip "T" and screw sleeve "S" home.

Assemble the main tube into the crown and top bracket. loosely tighten the top hexagon plugs "P" and finally tighten the nut "Y" below the steering damper knob. Finally tighten the two hexagon plugs "P" and *lastly* the two pinch bolts in the crown. Assemble mudguard, etc., in the ordinary way.

STEERING HEAD

The head bearings are of the cup and cone ball type and should be adjusted after the first few hundred miles running, after which they will require only infrequent attention. The front of the machine should be supported on a box under the engine and the front wheel clear of the ground. Loosen the top locknut "L" and gently screw the bottom nut "M" down until all clearance in the races has just disappeared and there is no sign of tightness in the steering. Then further tighten this nut "M" $\frac{1}{6}$ th of a turn, that is, turn the nut from one pair of flats on the hexagon to the next flats and no more. Hold this bottom nut "M" with the spanner to prevent it moving and securely tighten the top lock nut "L."

Lubrication.—Two grease gun nipples are provided for the two head bearings. Grease here every 1,000 miles.

STEERING DAMPER

The action of the steering damper is to make the steering much stiffer. It is extremely useful for combination work and high speed solo work, particularly on rough roads. Do not tighten up the damper more than is necessary, and remember to slacken it off whilst reducing speed, as stiff steering at low speeds is very unpleasant and, on occasions, very dangerous. The damper is controlled by the rotation of the black hand knob projecting above the centre of the handlebars; turning clockwise increases the damping.

To dismantle the damper, support the front wheel off the ground by means of a box under the engine.

To take out the centre tie rod which passes through the steering column remove damper knob and punch out the short steel parallel peg which is driven into and through the crown at the base of the column. The peg also passes through the brass trunnion piece connected to the end of the tie rod. Remove small damper plate anchor bolt and nut and the whole damper assembly can be withdrawn.

After lengthy service the fabric friction disc may require renewal otherwise no replacement should be necessary except in case of damage.

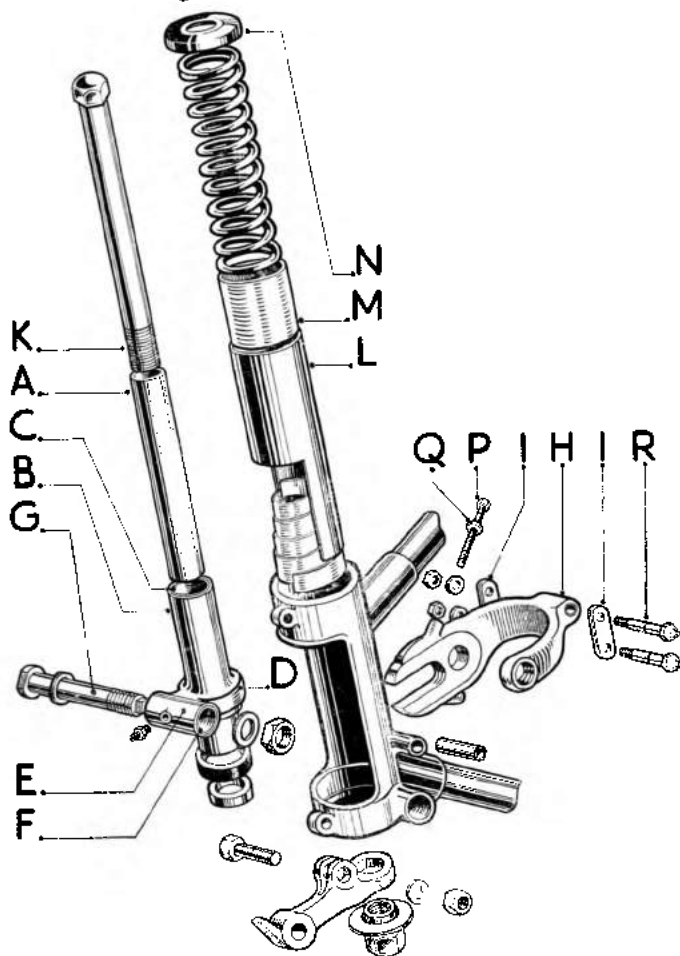

Fig. 26. Exploded view of Spring Frame.
SERIES A. MODEL KH

THE SPRING FRAME. SERIES "A" MODEL KH

Fig. 26

Construction.—The design of the sprung rear wheel is such that rear chain tension is maintained constant and the brake can be operated direct by the usual rod without the inter-position of any link mechanism or flexible cable. This perfect geometric pivoting of the wheel about the gearbox main shaft ensures maximum chain life and smooth braking.

The actual construction is as follows :—

Each rear fork lug has cylindrical extensions at the top and bottom. Fitted through the centre is a hardened guide tube A which is clamped to the lug by a substantial bolt K. On this tube is mounted the slider B with bushes C at each end. The spring abutment collar D is forged integral with the slider and extended rearwards to form a horizontal pivot boss E fitted with bush F. The pin G passing through this pivot supports each side of the stirrup H which surrounds the fork leg. The closed end of the stirrup is anchored to the chain stays by short links I, and one arm is extended to carry the wheel spindle. Renewable bushes are fitted to all bearings and the slider mechanism is completely enclosed against mud and dust by tubes L and M.

This combination of the straight line movement given by the slider B, and the small radius arc obtained by pivoting the stirrup just forward of the fork lug, gives a flat arc with centre at the gearbox driving sprocket, thus ensuring constant chain tension.

Assembly.—The dust excluding tube L is fitted into the cylindrical fork lug from the top, the cut away part facing backwards. Next drop in the thick packing washer and the short recoil spring. Place the slider B in position (short extension below collar D at bottom) and above the collar fit the dust tube M and the compression spring. Thread the aluminium collar N on to the bolt K and follow with the guide tube A. Now run this assembly down through the slider and thick packing washer until the end of the bolt projects through the bottom of the fork lug; screw on the domed nut and lock up solid. Check this nut periodically for tightness.

The fitting of the stirrup is quite straightforward. Note that the pivot **G** is fitted from the wheel side of the stirrup and screws into the short arm. Tighten the pin until the stirrup has no side float, then do up the locknut. The squared end of the pin facilitates subsequent adjustments when the head is masked by other fittings. Fit the two links and bolts from the closed end of the stirrup to the frame lug.

Lubrication.—The complete slider mechanism is lubricated by applying the grease gun to the nipple(s) on the slider boss marked “**E**” and to ensure a smooth and efficient action lubrication should be carried out every 250 miles. The short connecting link bearings are lubricated by grease gun application to the nipple headed link bolts **R**, Fig. 26. An early series of machines were however produced with plain link bolts fitted into oil impregnated bushes which do not require further lubrication but more frequent renewal may be necessary if the machine is in daily use.

THE SPRING FRAME SERIES “**B**” Model “**KH**” and “**KHA**”

FIG. 27

Construction.—The design of the sprung rear wheel is such that rear chain tension is maintained constant and the brake can be operated direct without the inter-position of any link mechanism. This perfect geometric pivoting of the wheel about the gearbox main shaft ensures maximum chain life and smooth braking.

The actual construction is as follows:—

Each rear frame fork lug has cylindrical extensions at the top and bottom.

Fitted into the centre is the slider **B** with bushes **C** at each end.

The spring abutment collar **D** is forged integral with the slider and extended rearwards to form a horizontal pivot boss **E** fitted with bush **F**.

The bolt **G** passing through the pivot supports each side of the stirrup **H** which surrounds the fork lug. The closed end of the stirrup is anchored to the chain stay frame tube by short links **I**, and one arm is extended to carry the wheel hub spindle. Renewable bushes are fitted to all link spindle bearings, and the slider mechanism is completely enclosed against mud and dust by tubes **L** and **M**.

Fitted through the centre of the slider is the main lug bolt **A** with a plain shouldered section at the lower end to fit into the steel bush **K** located in the base of the frame lug.

This combination of the straight line movement given by the slider **B**, and the small radius arc obtained by pivoting the stirrup just forward of the fork lug, gives a flat arc with centre at the gearbox driving sprocket, thus ensuring constant chain tension.

Assembly.—First press into position in the base of the frame lug the steel bush **K** followed by the rubber distance washer **S** and then the short flat steel recoil spring **U**. Place into position into the cylindrical lug from the top the dust excluding tube **L** with the cut away part facing backwards. Now place the slider **B** in position (Short extension below collar **D** at bottom) and above the collar fit the dust tube **M** and the main coil compression spring. Next insert the long lug bolt **A**, fit the domed lug cap **N** and loosely locate the plain washer and domed nut **T**. Next, compress the assembly together and fit the stand bracket **V** followed by the plain washer and bottom securing nut. Finally tighten the top domed nut **T**.

The fitting of the stirrup is quite straightforward. Note that the pivot pin **G** is fitted from the wheel side of the stirrup and screw into the short arm. Tighten the pin until the stirrup has no side float, then do up the locknut. The squared end of the pin facilitates subsequent adjustments when the head is masked by other fittings. Fit the two links and bolts from the closed end of the stirrup to the frame lug.

Lubrication.—The complete slider mechanism is lubricated by applying the grease gun to the nipple(s) on the slider boss marked “**E**” (Fig. 27) and to ensure a smooth and

efficient action, lubrication should be carried out every 250 miles. The short connecting link bearings are lubricated by grease gun application to the nipple headed link bolts marked R (Fig. 27).

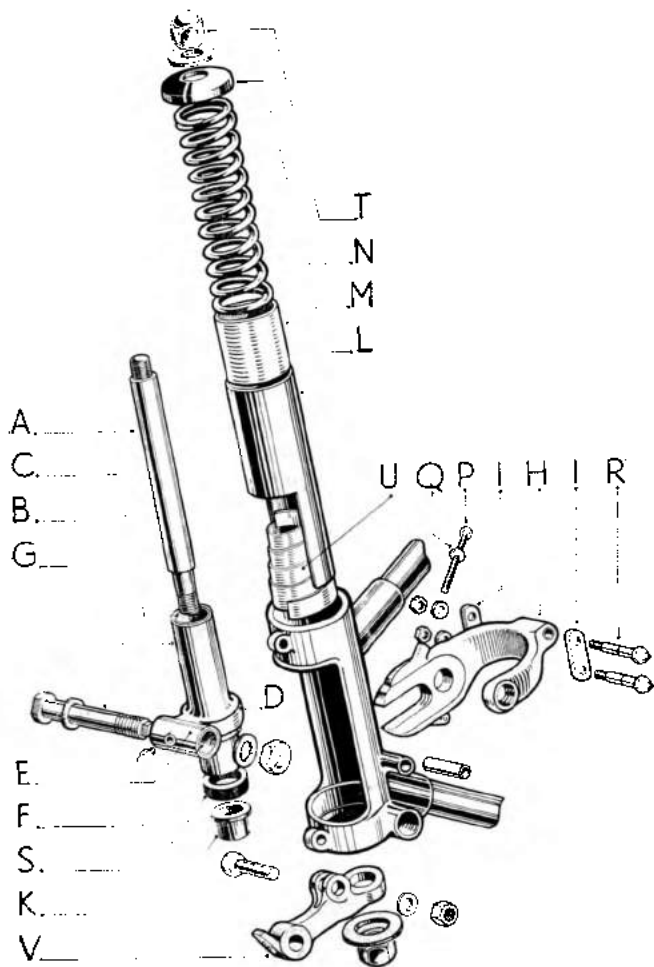

Fig. 27. Spring Frame Series "B".

Chain Adjustment.—The rear wheel fits into the forked ends of the stirrup arm H and adjustment is carried out by means of adjuster P (See Figs. 26, 27). Always check wheel alignment and adjust chain to allow $\frac{5}{8}$ in. movement at midway position between the sprockets.

Fixed Rear Wheel Removal.—This is carried out in exactly the same manner as on the rigid frame models.

Brake.—The actual brake construction and adjustment is again the same as on standard models. **Adjust the brake by means of the fulcrum adjustment.** The brake plate, however, is not secured to the spindle by means of a locknut, it is located endways by collars inside and outside the plate and is gripped and held securely when the wheel spindle nuts are tightened. The plate is prevented from rotating when the brake is applied by a protruding lug on the stirrup engaging with a slot in the brake plate. When refitting the wheel, be sure that the lug and slot are in engagement.

Bearings.—On the fixed wheel with spring frame the bearings are non-adjustable, being ordinary ball journal bearings. To remove or inspect the bearings, take out the wheel and remove the spindle nuts, collars and brake plate, etc., being careful to lay these down in correct order so that no mistake shall be made in reassembly. Prise off the dust cover at the brake end of the hub and unscrew the bearing locating ring in the other end of the hub. The wheel spindle has two shoulders forming abutments for each inner race. If the spindle is now driven or pressed out it will carry with it one bearing; the other bearing can then be removed by utilising the spindle again after taking off the bearing already removed.

DETACHABLE REAR WHEEL (RIGID FRAME)

Removal

To remove the detachable wheel, support the machine on the rear stand and pivot the complete rear mudguard upwards after releasing the dome nuts securing the rear stay. See also page 52.

Next remove the five wheel nuts securing the hub to the brake drum (a special spanner will be found in the tool kit) and then unscrew and withdraw the large centre spindle bolt.

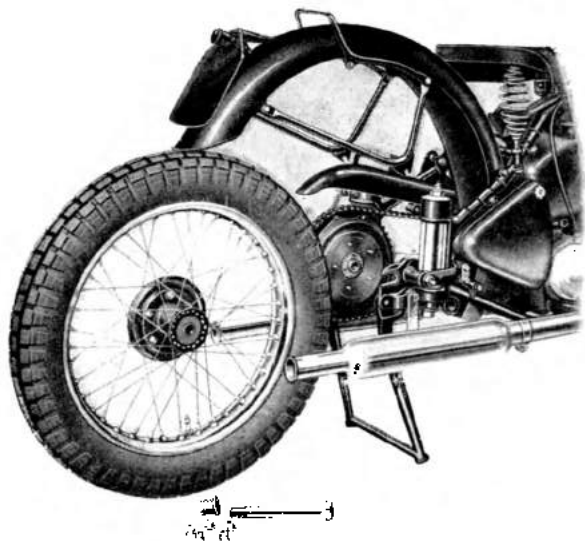

Fig. 28. Detachable Rear Wheel shown with spring Frame.

Note the position of the loose distance collar between the hub hollow spindle and the right-hand fork end and tap this away. Pull the wheel to the side clear of the five driving studs, leaving the complete brake drum with sprocket and rear chain in position (see Fig. 28). The wheel is replaced by reversing the procedure and care should be taken to ensure that the centre spindle and the five nuts are securely tightened.

Brake

The brake drum and chain sprocket are carried on a fixed spindle clamped in the nearside or left-hand rear fork end of the frame, and operates through the medium of a single journal ball bearing.

To remove the brake drum assembly it is generally most convenient to take out first the detachable wheel, but the wheel with drum assembly can be removed as a complete unit if desired.

Before attempting to remove the brake drum assembly it will be necessary to disconnect the brake rod, brake anchor bar and driving chain. Undo the spindle nut, and the brake plate complete with shoes can now be withdrawn from the drum. Take note of the position of the two plain distance collars, one on either side of the fork end and also the plain flat washer next to the large securing nut. Note also the two flats on the short spindle which register with the corresponding flats on the fork end.

Lightly grease the brake cam and fulcrum adjustment device; also brake cam spindle and joints.

When reassembling always see that spindle nuts are dead tight, brake anchor bar securely fixed, brake rod connected and adjusted and chain correctly fitted and aligned. See Fig. 17 for fulcrum adjuster position and always use this method for normal brake adjustment. A special spanner is provided in the tool kit for ease of operation. The adjuster thumb screw on the end of the brake rod should only be used to compensate for rear chain adjustment.

Bearings

One journal ball bearing ($\frac{3}{8}$ in. bore) is fitted to the detachable wheel hub and one similar ($\frac{1}{16}$ in. bore) to the brake drum assembly.

DETACHABLE REAR WHEEL (SPRING FRAME)

The complete detachable wheel for the spring frame is precisely the same as that for the rigid frame with the exception of the arrangement of distance pieces for fork end fixing, and the brake drum assembly brake plate. On the brake side a grooved distance collar is fitted between the brake plate and frame fork end and one thick washer outside the fork end next to the short spindle nut. On the right-hand or hub side a butted type slip collar is fitted between the hub and the fork end and one thick washer outside the fork end next to the head of the main spindle.

No rear brake plate anchor bar is fitted for spring frame models and the plate is prevented from rotating by a machined lug on the stirrup arm H engaging with a slot in the brake plate.

Wheel alignment and chain adjustment is carried out in the same manner as with the fixed wheel.

REAR CABLE BRAKE ADJUSTMENT

All normal brake adjustments should be carried out by means of the fulcrum arrangement. This square-ended screw situated in the brake plate must be turned clockwise to compensate for wear on the brake linings. Use the brake cable adjuster only to take up the slack in the flexible brake cable and to position the brake pedal to give just a trace of idle movement.

A special fulcrum adjuster spanner is provided in the tool kit. (See Fig. 29.)

To remove the wheel ball bearings, unscrew the right-hand side brass locking ring, bearing collar, and rubber grease retainer, and the bearing can then be driven out with a soft punch or drift from the left-hand or inner side of the hub. Reverse the procedure for refitting and well pack the bearing with grease.

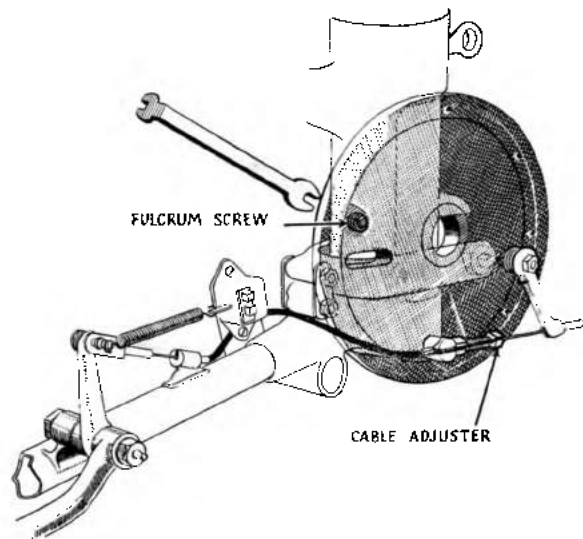

Fig. 29. Cable Brake Assembly.
Spring Frame and Detachable Wheel Models KH—KHA.

To remove the ball bearing from the brake drum assembly, first take out the brake plate (see previous notes) and then lift out the cork washer on the hub side. Next remove the large flat spring steel circlip and steel pressing and the short centre spindle can then be driven out from the brake side complete with ball bearing. Note how the bearing is held in position on the spindle by a wire circlip which must be removed before finally driving off the bearing. When replacing the bearing in the housing always well pack with grease.

PETROL TANK

The petrol tank is secured by four set bolts each having two rubber packing washers and one plain steel washer and secured with wire. The thick rubber washer goes next to the tank. The set bolts should not be screwed up too tightly, otherwise the base of the tank may be damaged and leakage occur.

Two separate two level taps are fitted and both main supply plungers should be "pulled on" when running, especially if a low level of petrol or gasoline is carried. When the main supply is exhausted pull on the Reserve Plungers, but take care still to leave the main plungers "on".

Ascertain how far the machine will travel after pulling on the reserve taps and you will then know for future use that fuel must be procured within this distance.

Always close the reserve taps after refilling the tank.

To simplify the above:—

To open main supply pull out knob "Pull on."

To open reserve supply pull out knob "Pull reserve."

The knob "Pull on" must also be left open.

To close tap push in both knobs.

To renew the corks.—Take out the small grub screw at the side of the tap and pull out the plunger complete. The cork end of the plunger rod can be held with pliers or grips and unscrewed. Fix new cork, replace plunger and adjust. Put back grub screw.

Use considerable care in handling the flexible petrol pipes. These pipes have only a limited degree of flexibility and will soon leak if bent too sharply or otherwise strained.

OIL GAUGE

The gauge is fitted into the top face of the petrol tank and secured by one nut and stud which passes through a short bracket welded to the tank. To remove the gauge the top oil pipe union must be disconnected and the petrol tank removed from the frame in order to give access to the gauge fixing stud nut.

SPEEDOMETER

The Chronometric Type instrument is fork mounted and driven by a flexible cable attached to the gearbox. To remove the cable from the driving end it is necessary to take out the small fixing screw in the face of the gearbox just below where the cable enters and it can then be pulled out of the housing. When refitting the speedometer flex into the gearbox it will probably be necessary to rotate the rear wheel slowly so that the flat metal tongue on the end of the inner cable can engage with the corresponding slot on the short driving spindle in the gearbox.

ADJUSTABLE FOOTRESTS

These consist of six parts. Two adjustable rests (with rubbers), two footrest supports, a footrest rod passing through the engine plates, and a distance tube between the plates. The rests are held on to the supports by a taper, the supports being held in position by the rod, and prevented from turning by two pegs on the engine plates which engage with recesses in the supports.

To remove or adjust the rests.—Slack off one nut on the end of the footrest rod until the spring washer is just free. With a heavy hammer or mallet give the inner end of the footrest a smart blow to release the taper: the direction of the blow must be such as to rotate the rest about the support. Strike the other rest in the same manner.

It is unnecessary to slacken the other nut and if the nut which is slackened is undone too far the support will disengage with the peg and rotate, so preventing the taper joint from being broken.

Set the rests in the position required and securely tighten up the nut.

FRONT STAND

Never use the front stand by itself. Always first place the machine on the rear stand and then swing the front stand down under the wheel until the stand is vertical. Do not let it touch the brake cam bearing or damage may be done to either the stand or the brake.

TYRE PRESSURES

The recommended **minimum inflation pressures** for Dunlop Cord Tyres in lbs. per sq. in. are as follows:—

<i>Model.</i>	<i>Tyre Size</i>	<i>Pressure (lbs per sq. in.)</i>		
K.H. SOLO	Front: 3.00—20	22
	Rear: 3.50—19	18
K.H. S CAR	Front: 3.00—20	28
	Rear: 3.50—19	26
	S CAR 3.25—19	17

All models, both solo and combination, may be fitted with spring frame, in which case pressure in rear tyres should be increased by 2lb. per square inch.

When a pillion passenger or additional load is carried the pressure in the rear tyre should be increased in accordance with the load and pressure schedule shown in the Dunlop booklet.

RUST PREVENTION

Most accessory dealers can supply a tin of rust preventative compound recommended for use on all chromium plated parts during the Winter months. Such a compound solution when applied to the metal, leaves a transparent protective film which can however, be easily removed with a little clean petrol or chromium plate special polish.

ARIEL MOTORS LIMITED

PROPRIETARY EQUIPMENT & ACCESSORIES

Although every effort is made to obtain the most suitable and highest quality fittings of a proprietary nature for incorporating into our Motor Cycles, our guarantee does not cover such parts.

In the event of trouble being experienced with proprietary fittings, the part or parts should be returned to and claims made direct on the actual manufacturers who will deal with them on the terms of their respective guarantees. Date of purchase and mileage covered should always be clearly stated when submitting a claim.

CARBURETTORS

Amal Ltd., Holford Works, Perry Barr, Birmingham 20.

CHAINS

The Renold and Coventry Chain Co. Ltd., Didsbury, Manchester.

MAGNETO AND ELECTRICAL EQUIPMENT

Messrs. Joseph Lucas Ltd. (Service Dept.), Great King St. and Great Hampton St., Birmingham, 19.

HORNS—ELECTRIC

Messrs. Joseph Lucas, Ltd. (Service Dept.), Great King St. and Great Hampton St., Birmingham, 19.

Clear Hooters, Ltd., 33, Hampton St., Birmingham, 19.

SADDLES

Messrs. Lycetts and Motor Accessories Co., Ltd., Ludgate Hill Passage, Birmingham, 3.

Messrs. Herbert Terry and Sons, Ltd., Redditch.

SPEEDOMETERS

Messrs. S. Smith (MA) Ltd., Cricklewood, London.

TYRES

The Dunlop Rubber Co., Ltd., Fort Dunlop, Birmingham.

SPARKING PLUGS

Lodge Plugs, Ltd., Rugby.

GEARBOXES

Messrs. Burman and Sons, Ltd., Wychall Lane, Kings Norton, Birmingham, 30.

TECHNICAL DATA

Description	Model	
	KH	KHA
Wheelbase in inches	56	56
Overall Length—inches	86	86
Handlebar width—inches	27	27
Ground Clearance—inches	5	5
Weight fully equipped—lbs.	384	370
Oil consumption—m.p.g.	2000	2000
Petrol Tank capacity—gallons	4	4
Solo Gear ratio —Top	5.20	5.20
" " " —Third	6.65	6.65
" " " —Second	9.15	9.15
" " " —Low	13.85	13.85
Sidecar Gear ratio —Top	5.75	5.75
" " " —Third	7.40	7.40
" " " —Second	10.15	10.15
" " " —Low	15.40	15.40
Engine Sprocket —Solo	21T	21T
" " " —Sidecar	19T	19T
Chain, Front $\frac{1}{2}$ in. Pitch		
No. of Links	81	81
Chain, Rear, $\frac{3}{8}$ in. Pitch		
No. of Links	95	95
Cylinder Bore	63 mm.	63 mm.
Engine Stroke	80 mm.	80 mm.
Engine b.h.p. at 6,500 r.p.m.	28	29
Cubic Capacity—actual	498 c.c.	498 c.c.
Compression ratio	L.C. 6.8	L.C. 6.8
	7.5 H.C.	7.5 H.C.

Spring Frame Models, 22lbs plus.

WHEN AND WHERE TO LUBRICATE EVERY 250 MILES

OIL	Check level in tank and top up if required.	
BA Gearbox	Clutch-operating lever pivot	1 point.
" "	Clutch-operating plunger	1 "
" "	Thrust points between lever and plunger	2 points.
GREASE	Spring frame when fitted	6 "
EVERY 500 MILES		
OIL	Replenish Primary Chain Case to "Oil Level" Plug	
	Check supply to Rear Chain	1 point.
	All Handlebar Controls and Cables Front and Rear Brake operation Pivots and Cable.	
	Outer End Brake Cam Bearings in each Wheel	2 points.
GREASE	Rear Brake Pedal Pivot	1 point.
BA Gearbox	Foot Gear Change, if Nipple fitted	1 point.
" "	Kickstart Crank, if Nipple fitted	1 "
" "	Speedometer Spindle, if Nipple fitted	1 "
EVERY 1,000 MILES		
GREASE	Steering Head Bearings	2 points.
	Rear Wheel Bearings	1 point.
OIL and GREASE MIXTURE	2-3ozs. in Gearbox. Approx 1 teacup For "BA" Gearbox.	
OIL	Top up level "GB" Gearbox	
EVERY 1,500 MILES		
	Drain Oil Tank and Sump, flush out and refill.	
EVERY 2,500 MILES		
OIL	Plain Dynamo Bearing Commutator	1 point.
GREASE	Withdraw Clutch Push Rod and grease lightly, including ball in Plunger	2 points.
	Front Hub (remove spindle)	1 point.

LUBRICATION RECOMMENDATIONS FOR 500 cc TWIN CYLINDER MODELS

	Vacuum	Shell	Wakefield	B. P. Energol	Esso
Engine					
Summer	Mobiloil BB	Shell X-100 Motor Oil 40	Castrol XXI	Energol SAE 40	Essolube 50
Winter	Mobiloil A	Shell X-100 Motor Oil 30	Castrol XL	Energol SAE 30	Essolube 30
Gearbox for mixture	Mobiloil BB	Shell X-100 Motor Oil 50	Castrol XXL	Energol SAE 50	Essolube 50
Oil Bath, Chain-Case and Rear Chain	Engine Oil	Engine Oil	Engine Oil	Engine Oil	Engine Oil
Wheel Hubs	Mobil Hub Grease	Shell Retinax A or RB	Castrolase Heavy	Energolase C ₃	Esso Grease
General Greasing	Mobilgrease No. 2	Shell Retinax A or CD	Castrolase CL	Energolase AO	Esso Grease
Telescopic Forks	Mobiloil A	Shell X-100 Motor Oil 30	Castrol XL	Energol SAF 30	Essolube 30
Normal Conditions					
Arctic Conditions	Mobiloil Arctic	Shell X-100 Motor Oil 20/20 W	Castrolite	Energol SAE 20	Essolube 20

INDEX

	<i>Page</i>		<i>Page</i>
BRAKES	52	FRONT FORK ASSEMBLY (Tele-	
Front Brake Adjustment ...	57	scopic with Hydraulic	
Front Brake Removal ...	55	Control)	58
Rear Brake Adjustment ...	54	Dismantling	64
Rear Brake Removal ...	52	Re-Assembly	64
CARBURETTOR	26	Steering Damper	65
Pilot Air Screw	26	Steering Head	65
Air Filter	27	FRONT STAND	77
CLUTCH	31	GEARBOX "BA" Type	31
Adjustment	31	Description of Parts	37
Body and Sprocket Removal ...	34	Dismantling	35
Description of Parts	32	Foot Gear Change Mechan-	
Gearbox and Clutch Assem-		ism	39
bly	31	Kick Starter	41
Plates, Removal and		Lubrication	42
Reassembly	34	Re-assembly	38
DRIVING CHAINS	51	Removal from Frame	34
Adjustment	71	GEARBOX "GB" TYPE	43
Lubrication	51	LUBRICATION	44
DYNAMO	30	LUBRICATION RECOMMENDATIONS	82
ENGINE	7	MAGNETO	27
Decarbonisation	15	Attention in Service	28
Description of Engine	7	Automatic Timing Device	28
Driving Hints	6	Dismantling the Magneto	29
Engine Lubrication Explained ...	10	Location of Faults	30
Engine Shaft Shock Absorber ...	27	OIL GAUGE	76
Erratic Running	5	PETROL TANK	75
Fuel Oil and Grease	3	PROPRIETARY EQUIPMENT AND	
How to trace Lubrication		ACCESSORIES	78
Faults	13	SPEEDOMETER	76
Instructions for Starting	4	SPRING FRAME	
Oil Tank and Filters	13	Series "A"	67
Running-in	3	Series "B"	68
Tracing Minor Troubles	4	Assembly	69
Valve Grinding	17	Detachable Rear Wheel	
Valve Tappet Clearance	23	(Spring Frame)	73
Valve Timing	23	Detachable Rear Wheel	
FOOTRESTS	76	(Rigid Frame)	71
		Lubrication	68, 69
		TECHNICAL DATA	80
		TYRES	77
		WHEELS	52
		Alignment	58
		Bearing Adjustments	54
		Fixed Rear Wheel Removal ...	52
		Front Wheel Removal	55
		Lubrication	55

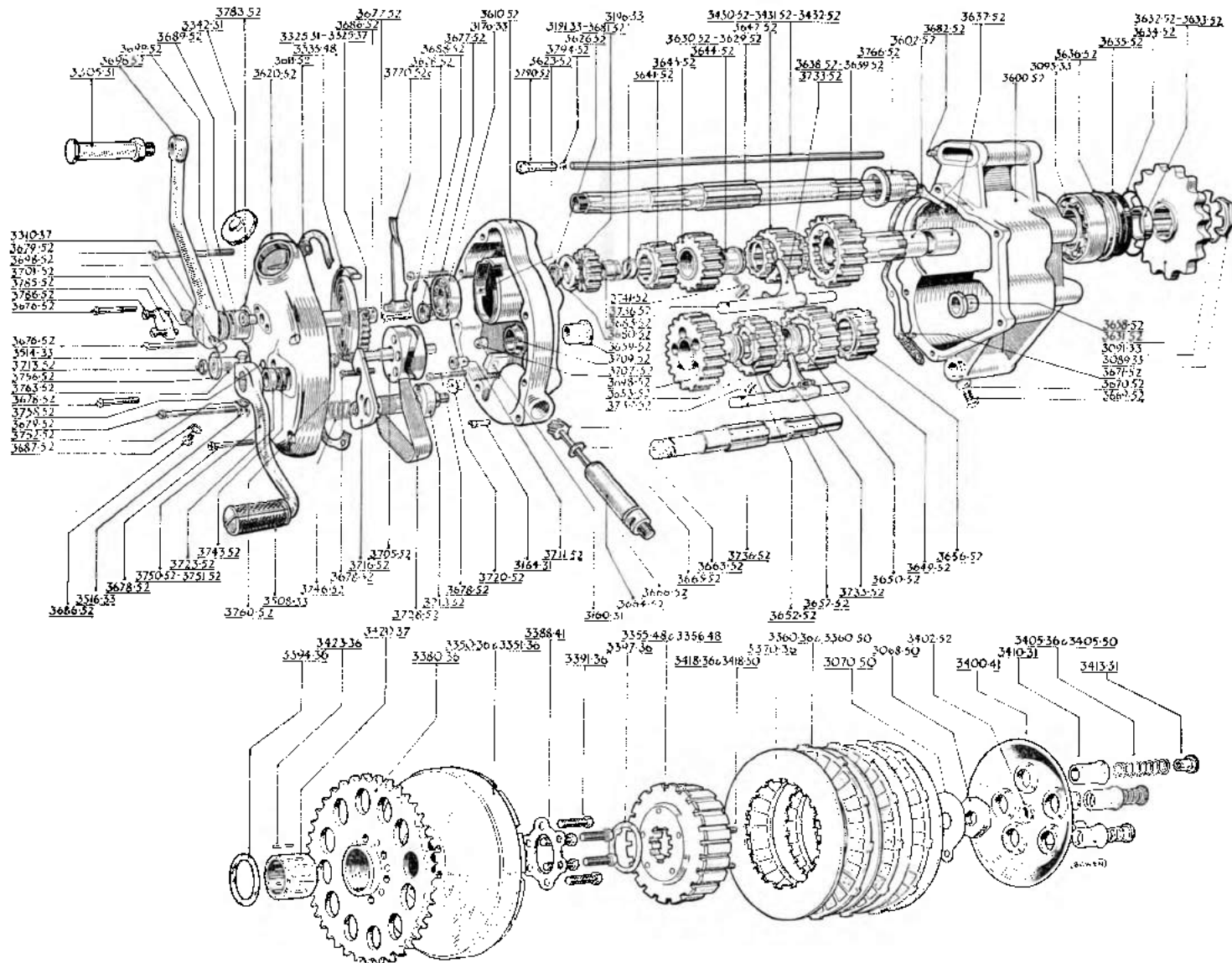

EXPLODED VIEW, TYPE GB GEARBOX & CLUTCH

(See page 34)

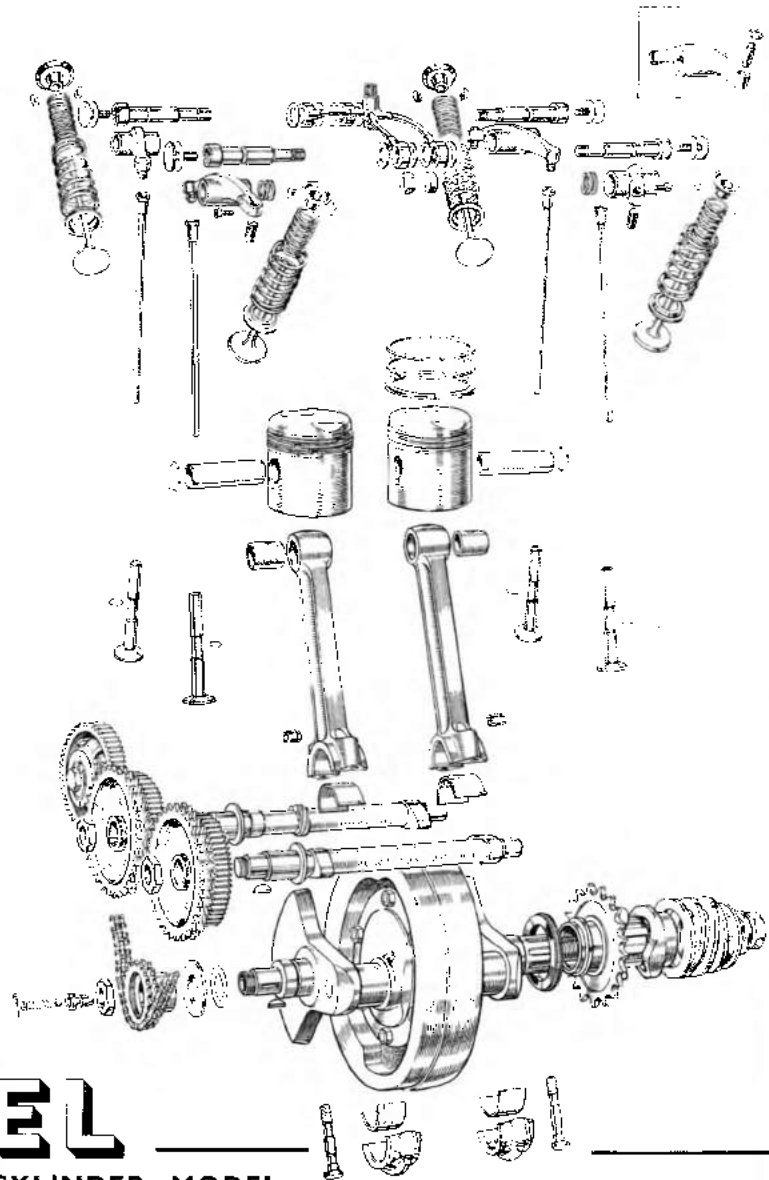
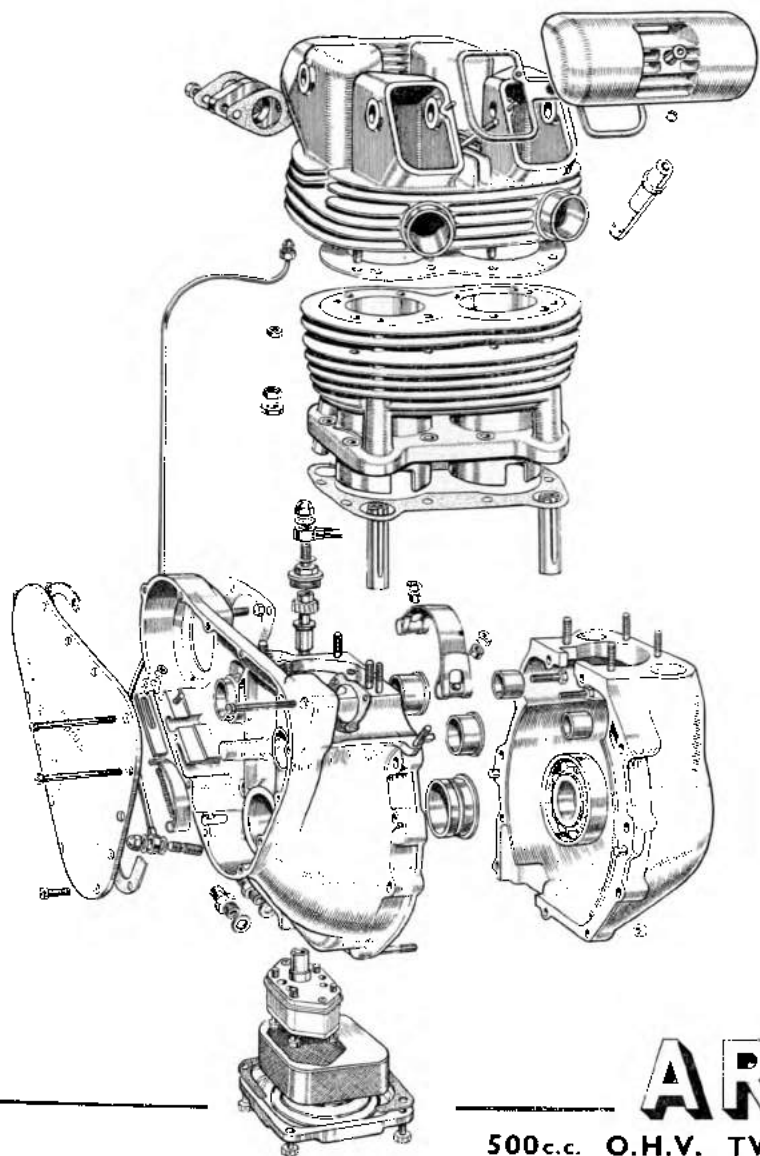

ARIEL

500c.c. O.H.V. TWIN CYLINDER MODEL
MODEL KH